

SECTION 3 DESIGN AND CONSTRUCTION REQUIREMENTS FOR CONVENTIONAL OWTS

CONTENTS

- A. DESCRIPTION
- B. SITING CRITERIA
- C. WASTEWATER FLOWS FOR OWTS DESIGN
- D. SEPTIC TANK REQUIREMENTS
- E. DISPERSAL SYSTEM REQUIREMENTS

FORMS AND FIGURES



SECTION 3

DESIGN AND CONSTRUCTION REQUIREMENTS FOR CONVENTIONAL OWTS

A. DESCRIPTION

Per San Mateo County OWTS Ordinance, a “Conventional OWTS” means a type of OWTS consisting of a septic tank for primary treatment of sewage followed by gravity flow to a system of drainfield trenches for subsurface dispersal of effluent into the soil.

B. SITING CRITERIA

The following minimum siting criteria must be met for approval of any conventional OWTS.

1. Accessible. OWTS must be located to be easily accessible for maintenance and repairs.
2. Within Property Boundaries. The septic tank, dispersal system, and other components of the OWTS shall be located within the boundaries of the parcel upon which the structure requiring the system is built.
3. Soil Depth. Soil of an accepted quality to receive effluent from the dispersal system shall extend a minimum depth of three (3) feet below the bottom of the dispersal trenches.
4. Soil Fill. No dispersal of effluent shall be allowed within soil fill.
5. Soil Cover. All dispersal systems shall have at least twelve (12) inches of soil cover.
6. Underground Utilities. Underground utility lines, conduits or trenches, including irrigation lines, shall not be installed across dispersal systems, nor shall they be located near dispersal systems so as to pose a potential preferential pathway for effluent.
7. Vertical Groundwater Separation. Minimum required vertical separation distance between trench bottom and groundwater shall be 5 feet.
8. Areas of Flooding. OWTS shall not be located in low-lying areas subject to annual flooding on the basis of flood mapping or historical evidence acceptable to Environmental Health staff.
9. Compacted Areas. OWTS shall not be located in areas subject to vehicular traffic or other areas subject to significant compaction, including areas of concentrated livestock use.
10. Ground Slope. Maximum ground slope in the conventional dispersal system area shall not exceed thirty-five (35) percent. Additionally, for any site where the



ground slope exceeds twenty percent, approval shall be dependent upon completion of a geotechnical report as provided in the County Ordinance and Section 2 of this Manual.

11. Soil Percolation Rate. The average soil percolation rate in the proposed conventional dispersal field area shall not be faster than 12 inches per hour (5 minutes per inch) nor slower than 1.00 inches per hour (60 minutes per inch), determined in accordance with procedures prescribed in Section 2 of this Manual (soil percolation rates of less than 1-inch per hour require pressure dosing as described in Section 4 of this Manual).
12. Horizontal Setbacks. Minimum horizontal setback distances from various site features to OWTS components shall be as listed in Table 3-1 below:



Table 3-1. Minimum Horizontal Setback Distances

Site Feature	Minimum Setback Distance (feet)	
	To Septic Tank	To Dispersal Field
Building or foundation	5	10
Septic tank	N/A	10
Property line		
-From properties served by wells or springs	50	50
-From properties served by approved public water supply	10	10
Swimming pool or spa	25	25
Road easement, pavement or driveway	5	5
Watercourses		
-General (from top bank)	100	100
-Between 1200 to 2500 feet from a public or State small water system intake	100	200 ¹
-Within 1200 feet downstream from a public or State Small water system intake	100	400 ¹
All wells and domestic/irrigation springs	100	100
Public and State small water system supply wells or springs	150	150
Reservoirs (from high water mark)		
-General	200	200
-Within 1200 feet from a public or State small water system intake	200	400
Groundwater interceptor trench or drain	5	25
Stormwater infiltration trench, gallery or well	25	25
Drainage ditch or swale (from edge of flow path)		
-General, lined or unlined	25	25
-Evidence of sustained wet conditions or ponding	25	50
Cuts or embankments (from top of cut)	10	4 x h ^{2,3}
Steep Slopes (lower in elevation than OWTS) ⁴		
-Height of steep slope less than 12 feet	10	25 ³
-Height of steep slope greater than 12 feet	10	50
Unstable land mass ⁵	100 ⁴	100 ⁴

¹ For areas tributary to and upstream of water supply intake; setback distance measure from high water mark. Exceptions may be allowed per SWRCB OWTS Policy, as follows:



- (a) for replacement OWTS, comply with the maximum extent practicable and incorporate supplemental treatment unless Environmental Health finds no impact or significant threat to water source;
- (b) for new OWTS on pre-existing lot of record (pre-May 13, 2013), comply to maximum extent practicable and incorporate supplemental treatment for pathogens per County Ordinance, Section 4.84.145 and prescribed by Environmental Health in this Manual.

² 'h' equals the height of cut or embankment, in feet. The required setback distance shall not be less than twenty five (25) feet nor more than fifty (50) feet.

³ Steep slope is considered to be land with a slope of greater than or equal to fifty percent (50%). Where there is clearly discernible embankment and/or break in slope, treat as Cut or Embankment. Setback of less than 50 feet must be confirmed by appropriate geotechnical evaluation, including but not limited to investigation of slope stability, evidence of rock or impermeable soil layers intersecting slope, seeps, or springs.

⁴ Setback distance may be reduced in accordance with recommendations provided in a geotechnical report prepared by a California civil engineer or professional geologist consistent with guidelines prescribed by Environmental Health in Section 2 of this Manual.

C. WASTEWATER FLOWS FOR OWTS DESIGN

1. Single Family Residences and Second Units. Wastewater flows used for design of OWTS for single family residences and second units are based on a factor of 150 gal/day per bedroom. The septic tank and dispersal systems for a primary residence and secondary dwelling unit shall be determined (as described in Section 3.D. and 3.E. below) based on total bedroom count where the primary residence and secondary dwelling unit share the same OWTS, and determined independently where the primary residence and secondary dwelling unit use separate OWTS.
2. Multiunit Residences and Non-residential Facilities. Wastewater flows used for the design of OWTS for multi-unit residences and non-residential projects shall be developed based on full consideration of projected activities, occupancy, and facilities. Guidelines provided in the 2002 US EPA Onsite Wastewater Treatment Systems Manual (Chapter 3) shall be used as the primary reference in estimating



design wastewater flows. For facilities not covered in the 2002 US EPA Onsite Wastewater Treatment Systems Manual, wastewater design flow shall be estimated based on either: (a) other appropriate literature references for the type of facility proposed; or (b) documented wastewater flow monitoring data for a comparable facility. Additionally, Environmental Health staff may consider case-by-case adjustment(s) of literature values based on more specific documented wastewater flow monitoring data. In all cases, the design proposal shall include sufficient technical information to support the proposed design flow estimate. Notwithstanding the above, minimum design flow for any OWTS shall not be less than 150 gpd.

3. **Flow Equalization.** Flow equalization is the process of controlling the rate of wastewater flow through an OWTS by providing surge capacity storage and timed-dosing of the incoming flow. Installed downstream from the septic tank, it allows peak surges in wastewater flow (e.g., from a weekend event) to be temporarily stored and metered into the treatment system and/or dispersal field at a relatively even (“average”) rate over an extended number of days (e.g., during the subsequent week). This generally aids OWTS performance.

Flow equalization may be used for non-residential and mixed use facilities that experience significant, regular and predictable fluctuations in wastewater flows. Examples of applicable facilities include, but are not limited to:

- Churches;
- Schools; and
- Special event venues.

Where flow equalization is proposed to be incorporated in an OWTS the following apply:

- the septic tank capacity shall be sized based on the peak daily flow for the facility;
- the design flow used for sizing supplemental treatment unit(s) and/or the dispersal system may be based on the equalized (“average”) flow rate rather than the peak daily flow rate for the facility;
- engineering calculations and specifications must be submitted substantiating the proposed design and operation of the flow equalization system; and
- an operating permit (per the County Ordinance Section 4.84.155 and this Manual) will be required.



D. SEPTIC TANK REQUIREMENTS

1. **Materials for Construction.** Reinforced concrete or other durable materials that are not subject to excessive corrosion or decay and which will produce a watertight tank shall be used. Interior surfaces of porous tanks require a coating, such as a water-based acrylic similar to Conseal CS-55 or a flexible polyurethane/polyurea elastomer similar to BASF's ElastoCast S55090R resin, or similar compound to minimize corrosion, typically meeting requirements of 40CFR261.4 for solid waste management. The coating shall extend from the top of the tank to six (6) inches below the water line.

Existing wooden septic tanks do not meet current septic code and must be replaced with appropriate septic tanks.

2. **Size of tank.** All septic tanks must have a minimum capacity of fifteen hundred (1,500) gallons or as specified below, whichever is greater.
 - a. For single-family residences and second dwelling units, minimum septic tank capacity shall be based on bedroom count as follows:
 - 1 - 4 bedrooms - 1,500 gallons
 - 5 – 6 bedrooms - 2,000 gallons
 - 7 – 8 bedrooms - 2,500 gallons
 - 9 – 10 bedrooms - 3,000 gallons
 - b. For multifamily and non-residential systems, minimum septic tank capacity shall be equal to at least two (2) times the peak daily wastewater flow for the facility served. Where a septic tank is employed in connection with a supplemental treatment system, the septic tank shall also meet minimum sizing requirements of the treatment system manufacturer, as applicable.

3. Design.

- a. Septic tanks for private residences shall be one (1) piece comprised of two (2) compartments with the first compartment containing two-thirds of the total tank volume.
- b. Septic tanks installed to serve other than individual residential structures shall meet the same requirements specified for private residences in (a) above. However, for larger flow OWTS exceptions will be permitted allowing the use of multiple tanks instead of a single (one-piece) tank.
- c. Each tank shall be structurally designed to withstand all anticipated loads, stress and weight. Tanks subjected to vehicular traffic shall be traffic-rated to State Department of Transportation Standard H20-44 truck loading standards.



Complete plans and design calculations shall be submitted for approval prior to installation.

- d. All septic tanks shall be approved by the International Association of Plumbing and Mechanical Officials (IAPMO) or stamped and certified by a California registered civil engineer as meeting the industry standards.
- e. The outlet of the septic tank shall be fitted with an effluent filter capable of screening solids in excess three-sixteenths (3/16) of an inch in diameter and conforming to NSF/ANSI Standard 46 or as otherwise approved by Environmental Health staff.
- f. Septic tank designs that differ from the above requirements may be considered by Environmental Health staff if supported by appropriate technical analysis demonstrating equal or better septic tank functionality and performance.

4. Location and Installation.

- a. The septic tank shall be located in a place accessible for vacuum pumping. Each compartment shall be provided with an access port extending at least to grade and covered with watertight, weight-bearing covers. Access openings shall be locked or otherwise secured to prevent unauthorized access.
- b. Where a setback variance is granted, a septic tank may be permitted closer than 5 feet, or under driveways provided it is traffic-rated and the septic tank is provided with a metal sewer access ring and cover over both compartments.
- c. No pumping of sewage from the house/building to the septic tank shall be permitted; gravity flow only shall be utilized.
- d. Tanks shall have a minimum of eight (8) inches of soil cover; however, as a minimum, tank access risers shall extend to grade.
- e. All connections from building to septic tank must conform to construction standards as required by the County or City building official, as applicable.
- f. **Water-tightness Testing.** All new septic tank installations and modifications to existing septic tanks shall undergo water-tightness testing as follows:
 - (1) **New Tanks.** For new tank installations, the testing shall be done with the risers in place and the inlet and outlet pipes plugged. The tank shall be filled with water to a level extending a minimum of two (2) inches into the risers, and monitored for a 1-hour period, with no measurable drop in the water level.



- (2) Existing Tanks. For existing tanks, the tank shall be filled with water to a level even with the invert of the outlet pipe, and monitored for a 1-hour period, with no measurable drop in water level. However, in cases where the groundwater level is known or estimated to rise above the level of the outlet pipe during any time of the year, the water-tightness test shall be conducted following the procedure for new tank installations (i.e., by filling the tank with water into the risers).

E. DISPERSAL SYSTEM REQUIREMENTS

1. Trench Specifications.

- a. Width. The width of the conventional dispersal system trench shall be a minimum of eighteen (18) inches and a maximum of twenty four (24) inches.
- b. Depth and cover. The depth of the standard conventional dispersal system trench shall be eight (8) feet deep with six (6) feet of properly graded clean $\frac{3}{4}$ - to 1½-inch rock fill beneath the distribution pipe (see Dispersal System Sizing – Residential) and extending at least two (2) inches above the top of the distribution pipe. The drain rock shall be covered with a layer of filter fabric and then with twelve (12) to eighteen (18) inches of uncompacted native soil. Trenches of greater than 8 feet depth may require a variance. No conventional dispersal system trench shall have less than 1 foot of rock beneath the distribution pipe.
- c. Trench Spacing.
 - (1) The minimum distance between standard (8-foot deep) dispersal system trenches shall be fifteen (15) feet, measured horizontally from the edges of adjacent trenches.
 - (2) For trench designs less than 8-foot deep, the minimum horizontal spacing between adjacent trenches shall be equal to two (2) times the sidewall depth of the trench; but in no case less than 6 feet.
 - (3) For sloping terrain, minimum trench spacing in conditions (1) and (2) above shall be increased by one (1) foot for each 5% incremental increase in slope above 20%.
 - (4) Where geological conditions indicate, an increase in the above spacing requirements may be necessary.
 - (5) Designated replacement trenches must maintain the same spacing from other trenches, whether installed or simply designated for potential replacement value.
- d. Diversion Valve. The total dispersal system shall be divided into two (2) equal lengths preceded by a diversion valve or equivalent device of approved design to allow for alternate use of each half of the dispersal system.



- e. On Contour. Each half of the dispersal system shall, whenever possible, be located on one contour (one elevation).
- f. Piping. Three (3) inch minimum diameter solid pipe schedule 40 PVC or stronger shall be used between the septic tank and dispersal system and between units of dispersal system trenches.
- g. Minimum/Maximum Length. Minimum length for a trench shall be twenty five (25) feet. Maximum length shall be one hundred twenty five (125) feet for gravity flow systems.
- h. Materials. The standard trench shall have six (6) feet of properly graded clean rock fill of $\frac{3}{4}$ to $1\frac{1}{2}$ inch size below the standard perforated drain pipe and extending at least two (2) inches above the top of the perforated drain pipe. The rock fill shall be covered with a protective layer of filter fabric and then with twelve (12) to eighteen (18) inches of lightly compacted (e.g., approximately 85%) native topsoil. Potential alternate materials, along with complete specifications, may be proposed to Environmental Health for consideration. Use of such alternate materials may require a variance with applicable fee.

2. Dispersal System Sizing – Residential.

Dispersal system sizing for single-family residential systems considers a standard 8-ft deep trench with 6 feet of drain rock beneath the distribution piping. For shallower trenches the equivalent infiltrative area is calculated based on the side-wall area beneath the distribution pipe, not counting the base of trench. Main house residential installations and main house with secondary dwelling unit using the same OWTS shall be in accordance with the following:

- a. For stabilized percolation rates of at least two (2) inches per hour but less than twelve (12) inches per hour:
 - (1) Up to three bedrooms – two lines each of seventy (70) linear feet;
 - (2) Each additional bedroom – add twenty (20) linear feet to each line.
- b. For stabilized percolation rates between one (1) inch per hour and one and ninety-nine hundredths (1.99)inches per hour:
 - (1) Up to three bedrooms – two (2) lines each of one hundred twenty five (125) feet;
 - (2) Each additional bedroom – add forty (40) feet to each line.



- c. For stabilized percolation rates between three-fourths (0.75) and ninety-nine hundredths (0.99) inches per hour:
 - (1) Up to three bedrooms – two (2) lines each of one hundred eighty (180) feet;
 - (2) Each additional bedroom – add sixty (60) feet to each line.
- d. Dispersal systems located in soils demonstrating percolation rates of between three-fourths (0.75) and ninety-nine hundredths (0.99) inches per hour shall utilize pressure dosing to distribute wastewater uniformly. See Section 4 of this Manual (Alternative OWTS) for additional requirements applicable to pressure distribution trench systems.
- e. No individual onsite wastewater treatment and disposal system which requires percolation of wastewater into the ground shall be approved where the stabilized percolation rate is less than three-fourths (0.75) inch per hour or more than twelve (12) inches per hour.
- f. Dispersal systems of lesser effective depths (<6 feet beneath distribution pipe) but equivalent effective sidewall infiltrative area may be permitted subject to the approval of Environmental Health.
- g. 100% reserve area equivalent to and separate from the proposed primary dispersal system area is required.

3. Dispersal System Sizing – Second Dwelling Units (separate OWTS).

Dispersal system sizing for second dwelling units considers a standard 8-ft deep trench with 6 feet of drain rock beneath the distribution piping. For shallower trenches the equivalent infiltrative area is calculated based on the side-wall area beneath the distribution pipe, not counting the base of trench. Secondary dwelling units of one (1) or two (2) bedrooms using a stand-alone OWTS (not connected to the main house OWTS) shall be in accordance with the following:

- a. For stabilized percolation rates of two (2) inches per hour but less than twelve (12) inches per hour:
 - (1) One bedroom (or studio) – two lines each of thirty (30) linear feet;
 - (2) Two bedrooms – two lines each of fifty (50) linear feet.
- b. For stabilized percolation rates between one (1) inch per hour and one and ninety-nine hundredths (1.99) inches per hour:
 - (1) One bedroom (or studio) – two lines each of forty five (45) linear feet;



- (2) Two bedrooms – two lines each of eighty five (85) linear feet.
 - c. For stabilized percolation rates between three-fourths (0.75) and ninety-nine hundredths (0.99) inches per hour:
 - (1) One bedroom (or studio) – two lines each of sixty (60) linear feet;
 - (2) Two bedrooms – two lines each of one hundred twenty (120) linear feet.
 - d. The requirements in Section 3.E.2.d. through g. above apply to second dwelling unit installations.
4. **Dispersal System Sizing – Multifamily and Non-Residential.** Dispersal system sizing for multi-family and non-residential installations shall be in accordance with the following:
- a. Design Flow. Design wastewater flow used for determining the required square footage and length of dispersal system trench shall be determined in accordance with the criteria in Paragraph C – Wastewater Flows for OWTS Design above; and
 - b. Wastewater Application Rates. The wastewater application rate(s) used for determining the required infiltrative surface area and overall trench length shall be based upon representative soil percolation test results for the soil zone corresponding with trench bottom depth, and the criteria in Table 3-2.
 - c. General Dispersal System Requirements. The requirements in Section 3.E.2.d. through g. above apply to multifamily and non-residential installations.

Table 3-2
Wastewater Application Rates for Drain Field Trench Sizing¹
For Multifamily and Non-residential Installations

Percolation Rate		Wastewater Application Rate (gpd/ft ²)
Inches /Hr	Min per Inch	
> 12	< 5	Not Permitted
12.0	5	1.20
6.0	10	0.80
2.5	24	0.60



2.0	30	0.56
1.5	40	0.49
1	60	0.35
0.75	80	0.20
< 0.75	> 80	Not Permitted

¹ Interpolate between reference values for other percolation rates; see attached table for expanded listing of interpolated values.

d. Effective Infiltrative Area.

(1) Standard Requirement. For trench sizing, the “effective infiltrative area” shall be limited to four (4) square feet per lineal foot of trench length, counting only trench sidewall area below the invert of the perforated distribution pipe.

(2) Deep Trench Exception. Under certain (favorable) soil and site conditions where deeper dispersal trench (e.g., up to 8-feet deep) construction is acceptable; the effective infiltrative surface may be increased up to a maximum of eight (8) square feet per lineal foot. This exception is limited to OWTS dispersal sites where: (a) ground slope is <20%; and (b) soil percolation rate is in the range of 2 inches per hour (30 mpi) to 12 inches per hour (5 mpi).

e. Trench Length Calculation. Required trench length for 100% capacity dispersal field shall be calculated as follows:

$$\text{Trench Length, } L = Q / (R * A)$$

Where:

Q = Design (peak) wastewater flow, gpd

R = Wastewater application rate, in gpd/ft²

A = Total infiltrative area per lineal foot of trench, in ft² (4ft² standard)

f. Dual System Requirement. Total dispersal trench capacity shall be provided for (2) 100% fields (primary and secondary) each sized per (d) above. Both primary and secondary fields shall be installed, and shall be equipped with an approved (manual) diversion device to allow alternating use of the two fields, typically switching between fields every 6 to 12 months.

5. Trench Construction.

a. Both the perforated drain tile pipe and the trench bottom shall be level.



- b. Perforated pipe shall be a minimum of 2,000 lb. Standard crush weight ASTM F810-8149232 or greater and shall be capped at the ends.
- c. Soil of an accepted quality to receive effluent from the drain field shall extend a minimum of three (3) feet below the dispersal system.
- d. Capped observation standpipes shall be installed at the end of each dispersal system trench, and extend from the bottom of the trench to ground level. The standpipe shall not be connected to the drain line.
- e. No dispersal of effluent shall be allowed within soil fill material.
- f. The dispersal system shall not be located under any paving or in an area subject to vehicular traffic.
- g. Underground utility lines, conduits or trenches, including irrigation lines, shall not be installed in or across dispersal systems, nor shall they be located near dispersal systems so as to pose a potential pathway for effluent.
- h. Trenches shall be constructed when the soil is dry. If moisture still remains in portions of the soil resulting in a smearing (sealing) effect on the sidewalls by the excavating equipment, the sidewalls shall be adequately scarified to restore the soil to its original drainage capacity.
- i. Trenches shall not be left without adequate cover overnight if rock fill is not added the same day as excavation.
- j. Appropriate erosion control measures must be employed during any excavation or earth movement activities.
- k. Environmental Health staff shall be notified for inspection at least twenty four (24) hours prior to the excavation of trenches.

6. **Construction Inspection.** At a minimum, inspection of conventional OWTS installation should include the items listed below. Joint inspection by the designer, contractor, and Environmental Health may be required.

- a. Pre-construction inspection where the construction staking or marking of the various system components is provided and construction procedures discussed.



- b. Open trench inspection of dispersal trench dimensions and conditions.
- c. Drain rock and perforated pipe materials and placement.
- d. Location and proper installation of diversion valve(s).
- e. Location, size, materials, and water tightness testing of septic tank.

- f. Final inspection to verify that all construction elements are in conformance with the approved plans and specifications, and final trench backfill/cover and erosion control has been completed.

Any field changes to the approved OWTS design shall be documented in a set of “as-built” drawings supplied to Environmental Health by the system designer, which shall be required before final written notice of installation approval is issued by Environmental Health.



FORMS AND FIGURES



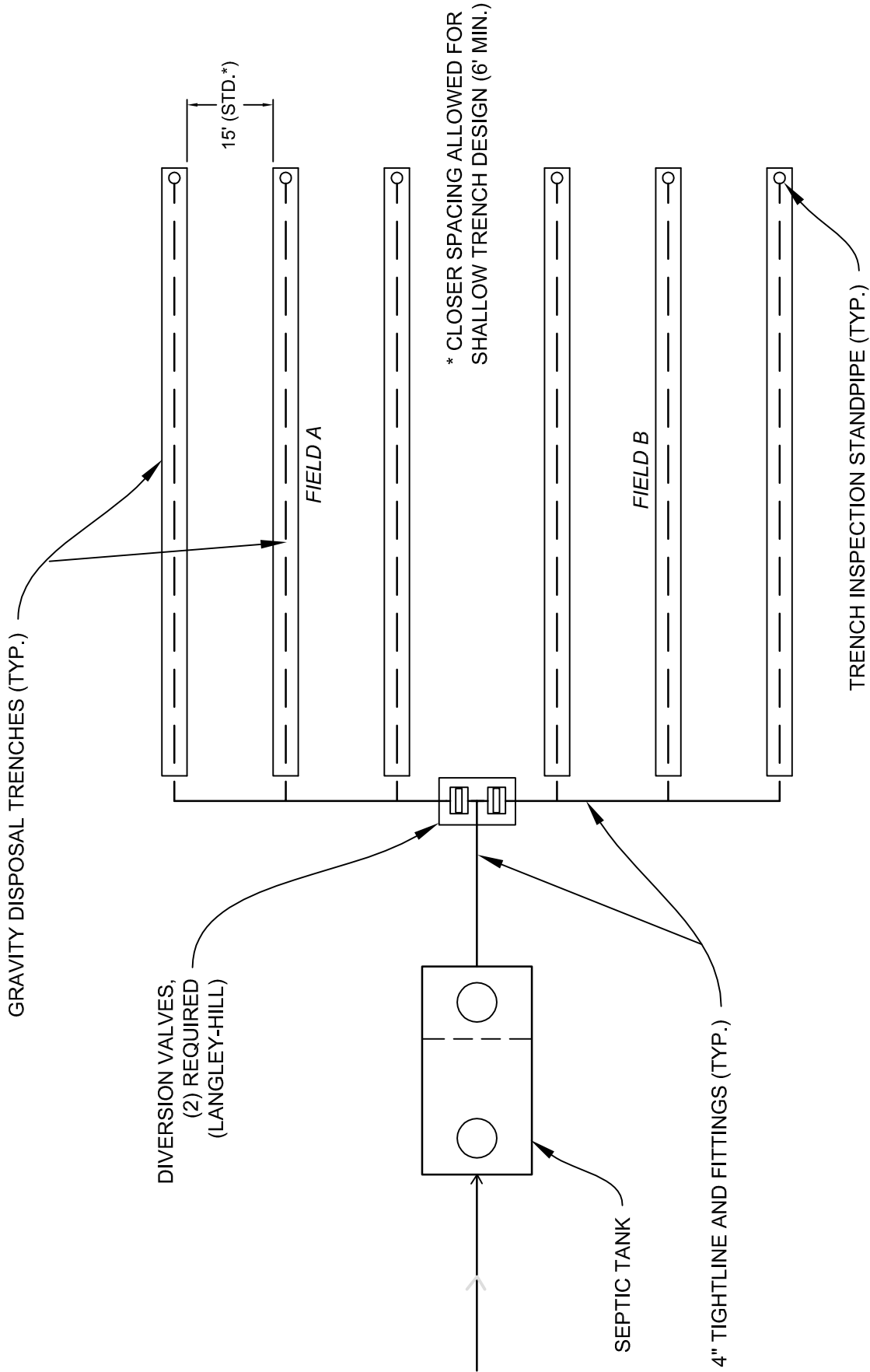

NOTE: ADDITIONAL 100% RESERVE AREA TO BE PROVIDED (NOT SHOWN)

FIGURE 3-1

CONVENTIONAL GRAVITY TANK AND DRAINFIELD SCHEMATIC

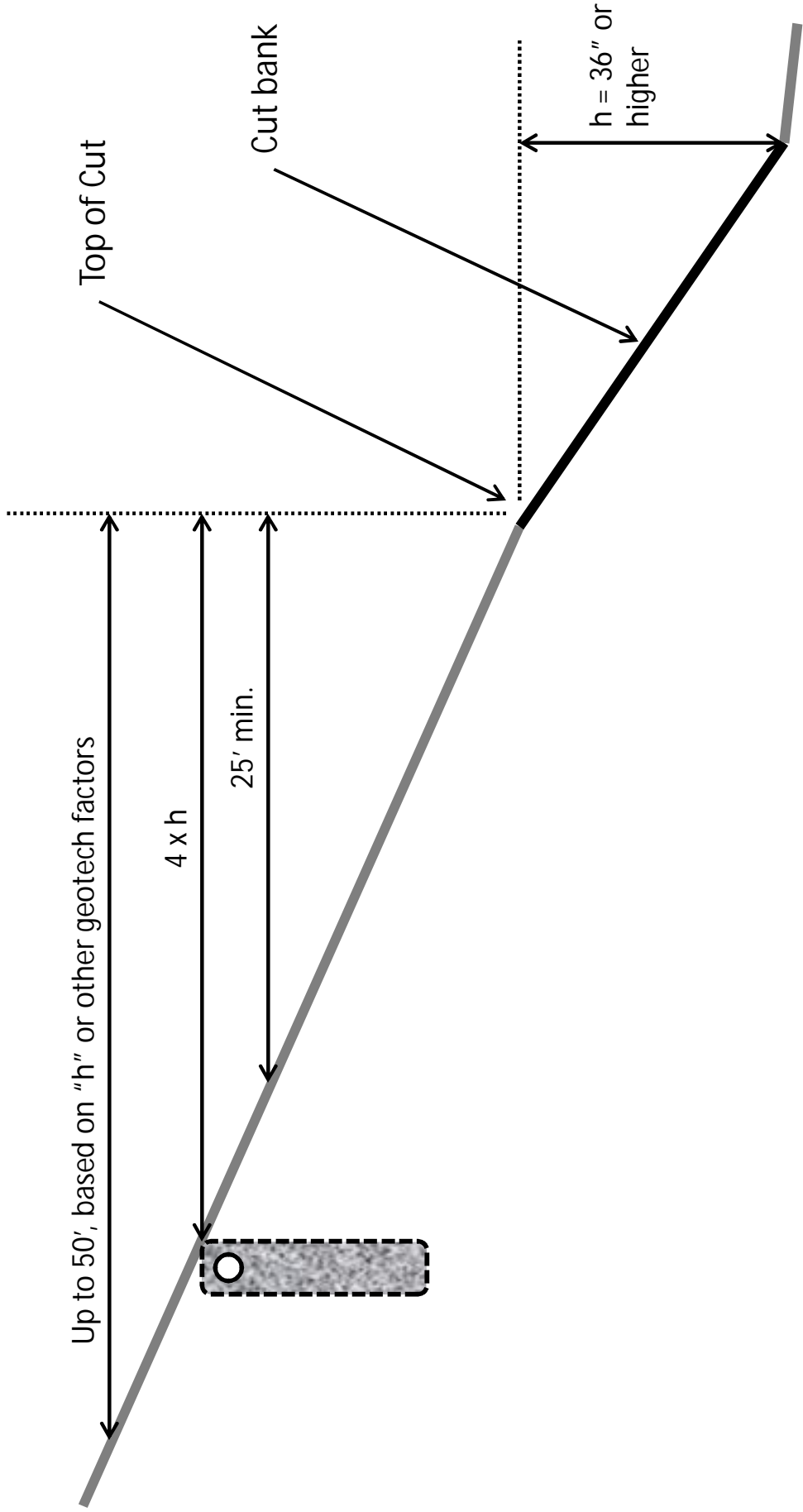

Setback to Cut or Embankment

FIGURE
3-2

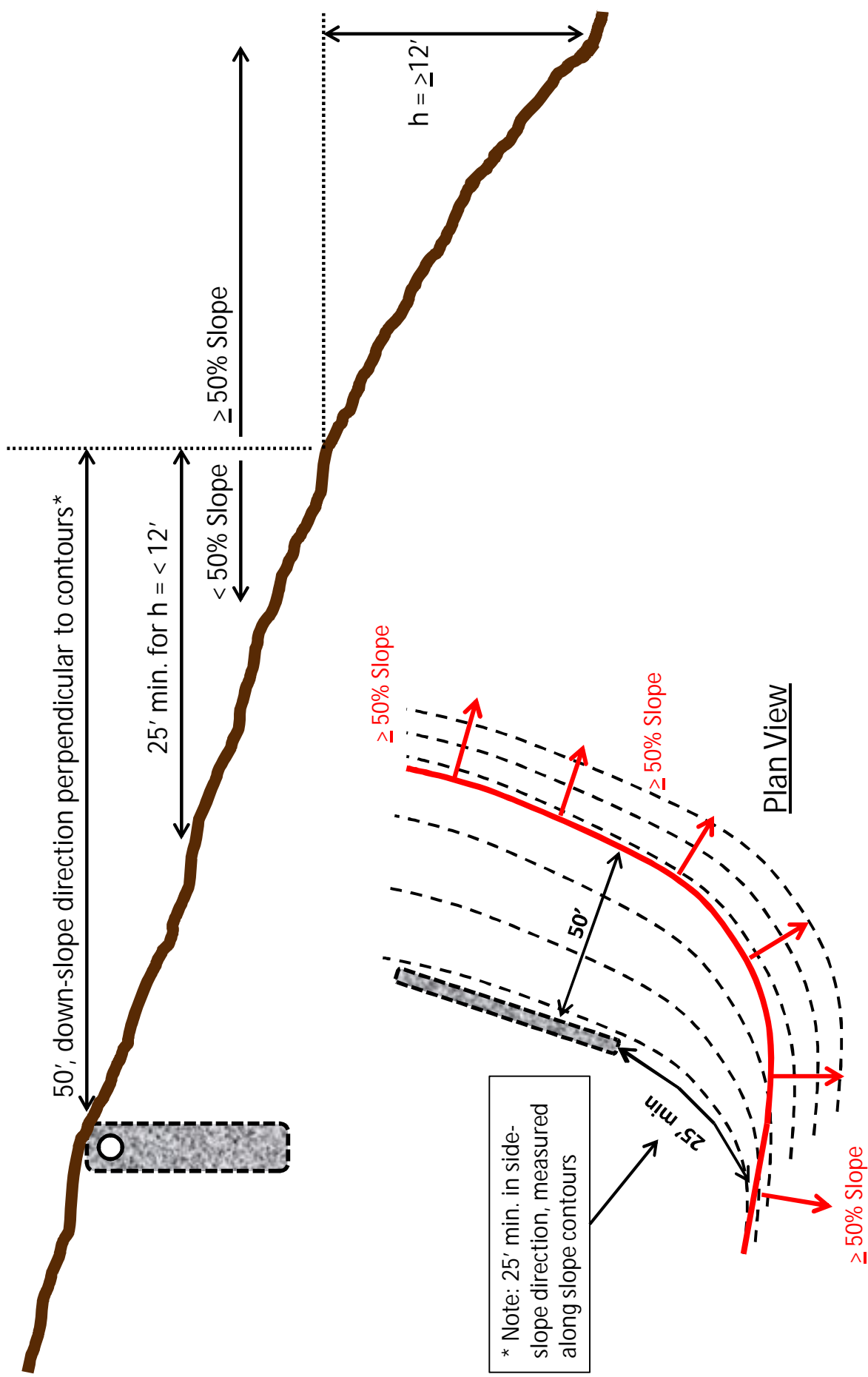

Setback to Slope of 50% or Greater

FIGURE 3-3

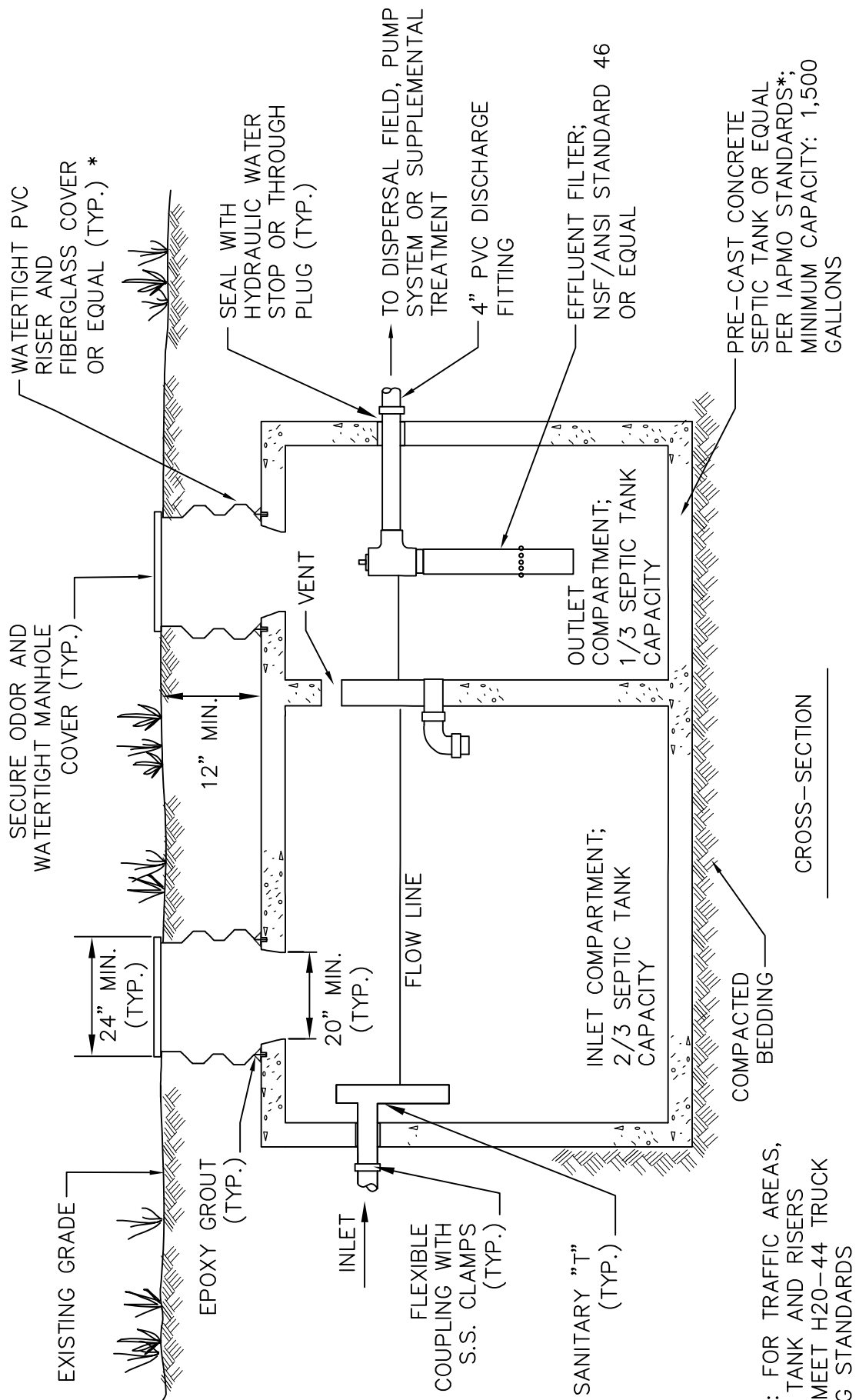

* NOTE: FOR TRAFFIC AREAS, SEPTIC TANK AND RISERS SHALL MEET H20-44 TRUCK LOADING STANDARDS

FIGURE 3-4

TYPICAL SEPTIC TANK

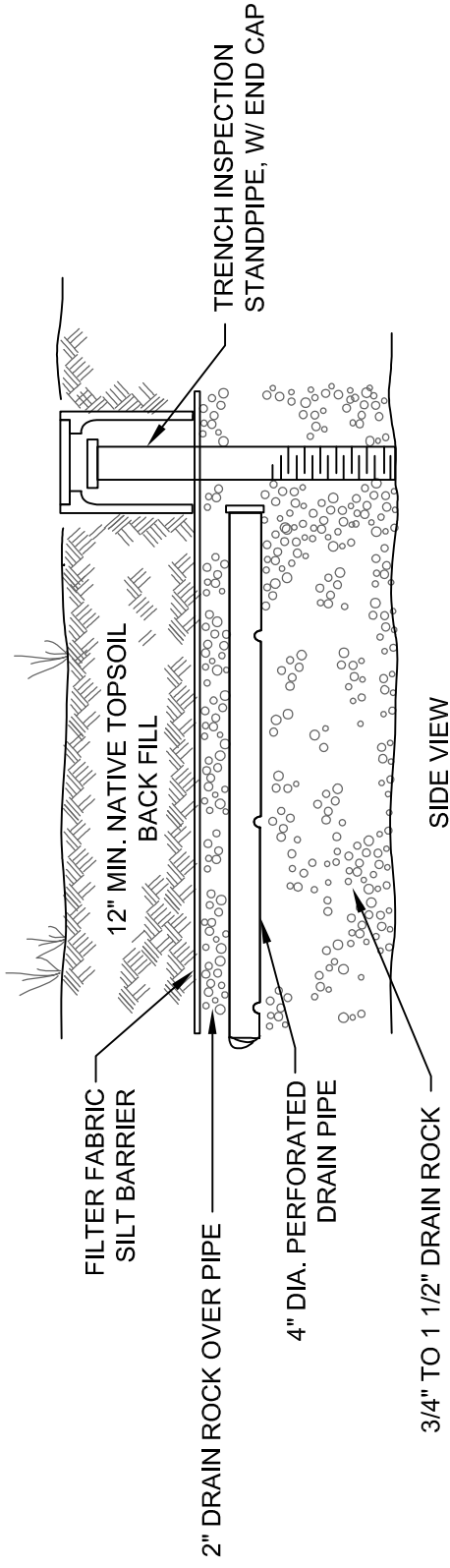

NOTES:

1. FOR RESIDENTIAL OWTS, DRAIN FIELDS OF LESSER DEPTHS (<6 FT. SIDEWALL DEPTH) BUT EQUIVALENT OVERALL SIDEWALL AREA MAY BE PERMITTED SUBJECT TO THE APPROVAL OF ENVIRONMENTAL HEALTH.
2. FOR MULTIFAMILY AND NON-RESIDENTIAL OWTS:
 - THE "EFFECTIVE INFILTRATIVE AREA" SHALL BE LIMITED TO FOUR (4) SQUARE FEET PER LINEAL FOOT OF TRENCH LENGTH, COUNTING ONLY TRENCH SIDEWALL AREA BELOW THE INVERT OF THE PIPE;
 - UNDER CERTAIN (FAVORABLE) SOIL AND SITE CONDITIONS, THE EFFECTIVE INFILTRATIVE SURFACE MAY BE INCREASED TO UP TO A MAXIMUM OF EIGHT (8) SQUARE FEET PER LINEAL FOOT.

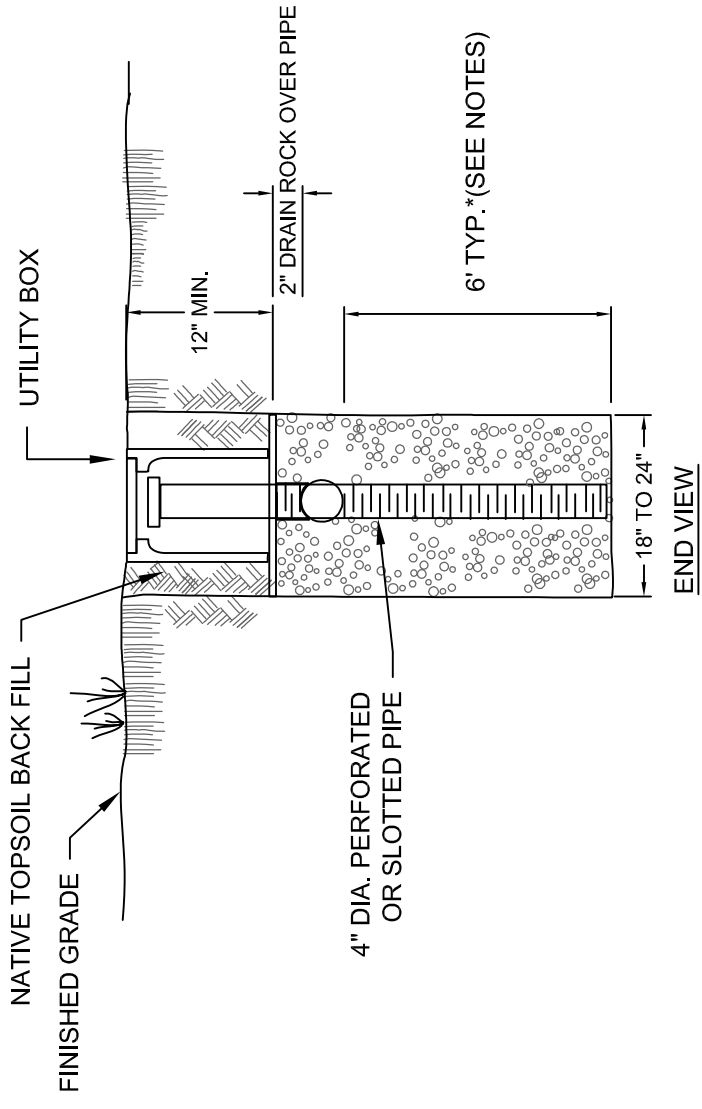
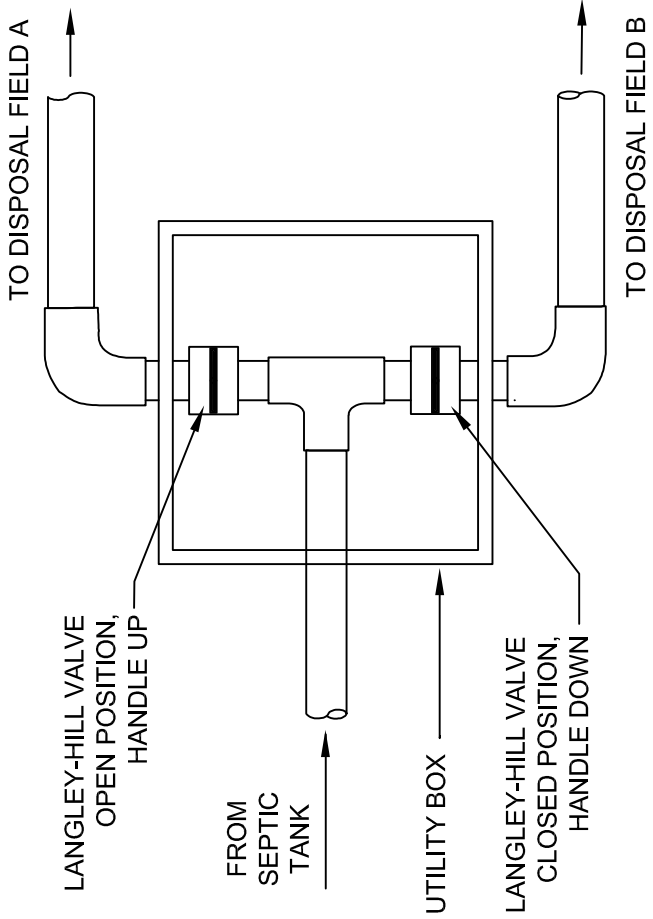
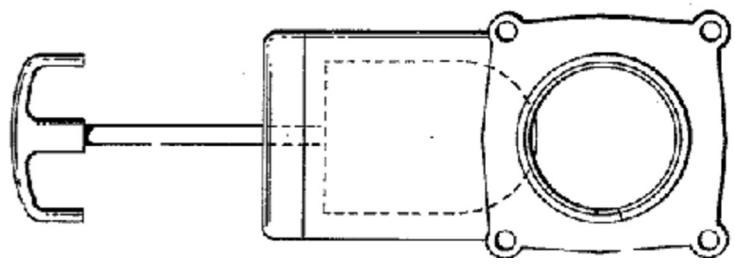

FIGURE 3-5

STANDARD GRAVITY TRENCH



PLAN VIEW



OPEN POSITION

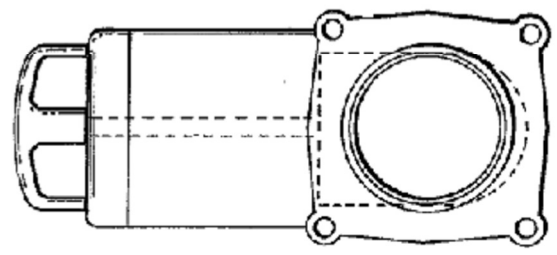

CLOSED POSITION

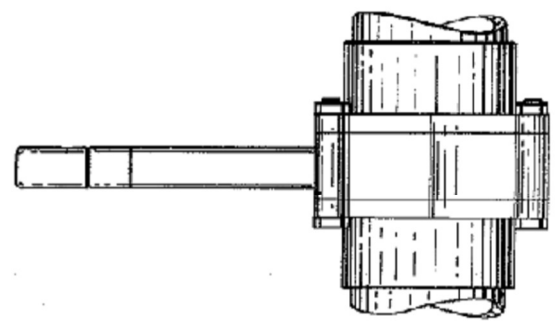

SIDE VIEW

SOURCE: U.S. PATENT #3,956,137
MAY 11, 1976

FIGURE
3-6

LANGLEY-HILL
DIVERSION VALVE