

SAN MATEO COUNTY ENVIRONMENTAL HEALTH DIVISION

SAFE DRUG DISPOSAL

STEWARDSHIP PLAN

PROPOSAL

Resubmittal January 19, 2023



SUBMITTED BY:



Contents

I.	Introduction	3
II.	Definitions	3
III.	Contact Information	6
IV.	Collection System For Unwanted Covered Drugs	6
	A. Convenience.....	6
	B. Kiosk Specifications And Design.....	10
	C. Mail-Back Envelope Program.....	13
	D. Collection Events.....	17
	E. Safety, Security And Patient Privacy.....	18
	F. Collector.....	19
	G. Drop Off Sites.....	19
V.	Handling And Disposal	20
VI.	Policies And Procedures	21
VII.	Public Education Effort And Promotion Strategy	25
	A. Promotion.....	25
	B. Standardized Instructions.....	25
	C. Website And Toll-Free Number.....	26
	D. Educational Materials.....	27
	E. Public Outreach.....	28
	F. Biennial Survey.....	30
	G. Language Translation.....	30
	H. Multiple Stewardship Plans.....	30
VIII.	Short-Term And Long-Term Goals	31
IX.	Additional Plan Considerations	32
X.	Administrative And Operational Costs And Fees	32
XI.	Reporting	33
XII.	Prior Approval For Plan Changes	34
XIV.	Appendix	35
	Appendix A: Participating Producers	36
	Appendix B-1: Authorized Collectors Offering To Participate In The Program	43
	Appendix B-2: Mail-Back Distribution Sites Offering To Participate In The Program	43
	Appendix B-3: Potential Drop-Off Sites Contacted By Inmar	44
	Appendix B-4: Potential Mail-Back Distribution Sites Contacted By Inmar	45
	Appendix C: Kiosk Signage, Mail-Back Inserts And Educational Brochure	61
	Appendix D: Training Material	67
	Appendix E: Public Outreach Material	84
	Appendix F: Applicable Permits And Licenses	89

Figures

<i>Figure 1: Kiosk Supply Auto-Replenishment Kit</i>	11
<i>Figure 2: Sample Standard Mail-Back Envelope</i>	14
<i>Figure 3: Sample Inhaler Mail-Back Envelope</i>	15
<i>Figure 4: Sample Auto Injector Mail-Back Package</i>	16
<i>Figure 5: Return Process Tracking</i>	22
<i>Figure 6: Inmar Serialization Tracking Form</i>	22
<i>Figure 7: Call Center Flow</i>	27

I. Introduction

Inmar submits this Stewardship Plan (“Plan”) for Unwanted Drugs in compliance with the San Mateo County Safe Drug Disposal Ordinance No. 04736 (“Ordinance”). All capitalized terms not otherwise defined shall have the same meaning as in the Ordinance.

Inmar’s Stewardship Plan will provide a comprehensive Safe Drug Disposal Stewardship Program that will include compliant drug Collection Methods supported by outreach and education programs to increase resident awareness and participation. The Stewardship Program will provide safe, secure, and convenient access on an ongoing basis for Residents across the County and will be funded by participating Covered Manufacturers. Producers represented by this Plan shall pay all administrative and operational costs and fees associated with the Stewardship Plan, pursuant to Section 4.116.030(e)(6). The program will also provide reporting on collection metrics and results of Resident education and outreach campaigns.

Some of the highlights of our plan are as follows.

- **Drug Collection Systems**
 - **Kiosk Service:** Turn-key program with DEA- and DOT-compliant processes and materials
 - **Mail-Back Services:** Available by request via a website or toll-free telephone number
- **Education & Outreach:** Strategic deployment of Inmar’s media assets and expertise, as well as far-reaching retail Pharmacy relationships to drive program awareness and participation
- **Annual Reporting:** Insight into required collection and outreach metrics

II. Definitions

This Plan uses and incorporates the definitions from the Ordinance. Additional definitions have been included that are not defined in the Ordinance but which help to clarify Inmar’s intent in proposing this Stewardship Plan. All defined terms are capitalized in the Plan.

Auto-injector (or Auto Injector) means an unused or partially used Pre-filled Injector Product with a retractable or otherwise securely covered needle.

Auto-Injector Mail-Back Package means a pre-paid, pre-addressed, FDA-cleared sharps container and outer shipment package for the collection and disposal of Pre-filled Injector Products.

County means the unincorporated and incorporated areas of the County of San Mateo.

County Residents (or “Residents”) mean human beings residing in the County.

Collector or **Authorized Collector** means a Person that gathers Unwanted Covered Drugs from County Residents for the purpose of collection, transportation, and disposal.

Collection System is Inmar’s term for the Collection Method that utilizes permanent collection Kiosks at fixed locations.

Collection Method means one of the three Collection types (Kiosk, Mail-Back, or Event) authorized for collection and disposal of home-generated Controlled substances by the DEA under 21 CFR Section 1317.

Container means the cardboard box which both supports the Inner Liner inside the Kiosk during drug collection and becomes the outer shipping package when the Inner Liner is full and/or removed from the Kiosk.

Covered Drug means a drug in any form used by County Residents, including prescription, nonprescription, brand name and generic drugs. Notwithstanding the previous sentence, "Covered Drug" does not include: (1) vitamins or supplements; (2) herbal-based remedies and homeopathic drugs, products, or remedies; (3) cosmetics, shampoos, sunscreens, toothpaste, lip balm, antiperspirants, or other personal care products that are regulated as both cosmetics and nonprescription drugs under the federal Food, Drug, and Cosmetic Act (Title 21 U.S.C. Chapter 9); (4) drugs for which Producers provide a pharmaceutical product stewardship or take-back program as part of a federal Food and Drug Administration-managed risk evaluation and mitigation strategy (21 U.S.C. § 355-1); (5) Drugs that are biological products as defined by 21 C.F.R. § 600.3(h) as it exists on the effective date of this chapter if the Producers already provides a pharmaceutical product stewardship or take-back program; and (6) medical devices or their component parts or accessories.

DEA means the U.S. Drug Enforcement Administration.

DEA Rule means the DEA Final Rule, "Disposal of Controlled Substances," 79 Fed. Reg. 53520 *et seq.* adopted on September 9, 2014 and codified at 21 CFR 1317.

Division means the Environmental Health Division of the County of San Mateo's Health System.

Director means the Director of the Environmental Health Division.

DOT means the U.S. Department of Transportation.

Drop-door means the door on the Kiosk where Unwanted Covered Drugs are deposited by Residents.

Drop-Off Site means a location which hosts an Inmar Kiosk for the collection of Unwanted Covered Drugs and is operated by an entity which has registered with the DEA as a collector of controlled substances under 21 CFR Section 1317.

Inhaler Mail-Back Envelope means a pre-paid, pre-addressed envelope for the collection and disposal of inhalers.

Inmar Plan means the Product Stewardship Plan presented in this submittal.

Inner Liner means the liner placed inside the Container which meets the requirements of 21 CFR Section 1317.60.

Kiosk means a metal receptacle into which Residents deposit Unwanted Covered Drugs and which meets the requirements of 21 CFR Section 1317.

Kiosk Drop-off Service means a Collection Method in which Residents deposit Unwanted Covered Drugs into a Kiosk operated by an Authorized Collector at an Authorized Collection Site.

Liner Kit is a set of three (3) pre-labeled and pre-paid cardboard box Containers, liquid barriers, and serialized, puncture-resistant Inner Liners.

Law Enforcement Agency or LEA is a Federal, State, tribal, or local law enforcement office or agency.

Manufacturer (or Covered Manufacturer) means a Person engaged in the manufacture of drugs.

Mail-Back Distribution Site means a location at which Residents may obtain Mailers at no charge and which is provided by Inmar to meet the Service Convenience Goals established in the Ordinance.

Mail-Back Services means a Collection Method for the return of Unwanted Covered Drugs from County Residents utilizing prepaid and pre-addressed Mailers.

Mail-Back Starter Kit means 20 Standard Mail-Back Envelopes with a visual reorder trigger, with instructions to Standard Mail-Back Distribution Sites on how to reorder additional Mail-Back Starter Kits.

Mailer is Inmar's generic term used to refer to all pre-paid, pre-addressed Standard and Inhaler Mail-Back Envelopes and Auto-Injector Mail-Back Packages.

Packaged Container means the full Inner Liner used in the Kiosk Drop-off Service after it is removed, secured within the Container, prepared, and sealed for transportation to a DEA Reverse Distributor.

Pharmacy means a place licensed by the state of California Board of Pharmacy where the practice of Pharmacy is conducted.

Pharmacy Employee means the designated contact person or persons at the Kiosk Drop-off Site.

Pick-Up and Disposal Coordination Option means the method of Packaged Container disposal which an Authorized Collector selects when participating in the Inmar Plan. The three options, Self-Service Return, Technician-Assisted Return, and Full-Service Return, are described in detail in Section V (c) of the Inmar Plan.

Producer means a Manufacturer engaged in the manufacture of a Covered Drug sold in the County, including a brand-name or generic drug. Notwithstanding the previous sentence, "Producer" does not include: (1) a retailer whose store label appears on a Covered Drug or the drug's packaging if the Manufacturer from whom the retailer obtains the drug is identified under Section 4.116.030(d) of this chapter; (2) a repackager if the Manufacturer from whom the repackager obtains the drug is identified under Section 4.116.030(d) of this chapter; (3) a pharmacist who compounds or repackages a prescribed individual drug product for a consumer; or (4) a wholesaler who is not also the Manufacturer.

Program Operator means a Producer, group of Producers or Stewardship Organization that develops and implements, or plans to develop and implement, a Stewardship Program approved by the Division.

Retail Pharmacy means a Pharmacy licensed by the state of California Board of Pharmacy for retail sale and dispensing of drugs.

Standard Mail-Back Envelope means a prepaid and pre-addressed Mail-Back Envelope for the collection and disposal of all Unwanted Covered Drugs except for those dispensed in an inhaler or Auto-injector.

Stewardship Plan means a plan for the collection, transportation and disposal of Unwanted Covered Drugs required under Section 4.116.040 of the Ordinance that is: (1) financed, developed, implemented and participated in by one or more Producers; (2) operated by the participating Producers or a Stewardship Organization; and (3) approved by the Director.

Stewardship Program (Program) means the program that Inmar will operate under a Plan approved by the Division.

Stewardship Organization means an organization designated by a Producer or group of Producers to act as an agent on behalf of one or more Producers to develop and implement and operate a Stewardship Plan.

Supervisory District means the districts of the County of San Mateo as defined in San Mateo County Ordinance Code Chapter 2.02 or its successor.

Unwanted Covered Drug means any Covered Drug that the owner has discarded or intends to discard.

III. Contact Information

Ordinance 04736 Section 4.116.040(a)

A list of Producers who agreed to participate in Inmar’s Stewardship Plan in San Mateo County is provided in Appendix A. These Producers will pay all administrative and operational costs and fees associated with the Stewardship Plan, pursuant to Section 4.116.030(e)(6).

For additional questions, contact:

Nick Massaro,
Senior Manager, Consumer Drug Take Back Solutions
1 W. 4th Street
Winston Salem, NC 27101
Email: nicholas.massaro@inmar.com
Phone: 336-770-1992

IV. Collection System for Unwanted Covered Drugs

Ordinance 04736 Section 4.116.040(b)

A. Convenience

Ordinance 04736 Section 4.116.050(b)(1)

Ordinance 04736 Section 4.116.050(b)(3)

Inmar will set up a Collection System that provides convenient and equitable access to Residents across the County as outlined in the Ordinance 04736 Section 4.116.050(b)(1). Drop-off sites are searchable to Residents in Google Maps, simply by typing “Drug Disposal,” or other similar phrases in the Google Maps applications.

Pursuant to Ordinance No. 04736 Section 4.116.050(b)(1) Inmar will seek to establish a minimum of one Drop-off Site for every 20,000 Residents throughout the County, geographically distributed to provide reasonably convenient and equitable access. We will ensure there are never less than five Drop-off Sites per Supervisorial District, as required by Ordinance No. 04736 Section 4.116.050(b)(1).

In accordance with Section 4.116.050(b)(3) of the Ordinance, Inmar will give preference to locating Drop-off Sites at Retail Pharmacies and law enforcement agencies (LEAs). Additionally, Inmar will prioritize locating Drop-off Sites in areas not served by other approved Plan Operators. A person may offer to serve as a Collector voluntarily or may agree to serve as a Collector in exchange for incentives or payment offered by Inmar pursuant to Section 4.116.050(a) of the Ordinance.

The below charts represent Inmar’s plan to meet the convenience standard described above. The data used comes from the County of San Mateo 2017-2019 Profile from the City Manager’s Office (<https://www.smcgov.org/media/3181/download?inline=>). According to known population data, Inmar will plan to provide a minimum of 51 Drop-off Sites in the County. Drop-off Sites will be established across all 5 Supervisorial Districts and in unincorporated areas based on population. As presented, Inmar will exceed the minimum requirements of 5 Drop-off Sites per district. Appendix B-1 includes a list of locations confirmed as Authorized Collectors.

Districts	# of Kiosks (minimum)
District 1 – Dave Pine	10
District 2 – Carole Groom	9
District 3 – Don Horsley	11
District 4 – Warren Slocum	9
District 5 – David Canepa	12
Total	51

City	Population	Supervisorial District	# of Kiosks (minimum)
Atherton	7,167	3	1
Belmont	27,218	2,3	2
Brisbane	4,282	5	1
Burlingame	30,459	1	2
Colma	1571	5	1
Daly City	106,562	5	6
East Palo Alto	29,662	4	2
Foster City	33,477	2	2
Half Moon Bay	12,657	3	1
Hillsborough	11,451	1	1
Menlo Park	33,449	4,3	2
Millbrae	22,795	1	2
Pacifica	39,260	3	2
Portola Valley	4,353	3	1
Redwood City	85,288	4	5
San Bruno	43,185	1,5	3
San Carlos	29,931	3	2
San Mateo	105,536	2	6
South San Francisco	67,271	1,5	4
Woodside	5,561	3	1
Unincorporated	64,000	1,3,4,5	4
San Mateo County Total	765,135		51

Procedures for finding and contacting potential Collectors

Appendix B-3 includes a list of potential locations contacted by Inmar which would utilize a Kiosk as the Collection Method upon becoming a Collector.

When determining eligible Retail Pharmacies for potential Kiosk locations Inmar uses the National Registry of Pharmacies, as well as looking at current clients who qualify and who do not currently participate with other approved Plan Operators. Other online resources are used for determining eligible LEAs and potential Mail-back Distribution Sites such as county and city websites, SAMHSA (Substance Abuse and Mental Health Services Administration), etc. Contact is then made by letter, email and/or phone.

List of Law Enforcement Agencies Contact by Inmar

Inmar made attempts to contact the following LEAs that do not currently participate as Authorized Collectors. Notes from the calls are included below. Inmar will continue to reach out to the Atherton Police Department and Colma City Police Department in an attempt to place Kiosks for the Program.

Atherton Police Department	83 Ashfield Road, Atherton, CA 94027	Contacted 1/10, 1/12, 1/17 - no response to date
Foster City Police Department	1030 E Hillsdale Blvd, Foster City, CA 94404	1/10/2023 - spoke with the Chief Asst. The PD leadership chose not to participate in the Program because their lobby is too small for placement of a Kiosk and the greater area around the PD is already saturated with Kiosk placements including two blocks from the PD at CVS.
Colma City Police Department	1199 El Camino Road, Colma, CA 94014	Contacted 1/10, 1/12, 1/17 - no response to date

Annually, Inmar will review any potential Authorized Collection locations against the Board of Pharmacy License directory to validate if the location holds an active retail, hospital or clinic license. Additionally, sites will be required to provide evidence of current DEA registration. Inmar will notify the Director as new Authorized Collection Sites become operational. Such notification will include the Authorized Collector’s contact information.

Inmar will establish mail-back distribution locations to supplement service in any area underserved by Drop-Off Sites. Inmar currently has Rx Returns clients in San Mateo County, of which many are Retail Pharmacy clients. Inmar will evaluate and contact these Retail Pharmacies as potential Drop-Off Sites or Mail-Back Distribution Sites as needed. Inmar will utilize hospitals with on-site Pharmacies and law enforcement agencies as necessary to meet the goals of equitable and reasonably convenient access for Residents across San Mateo County. However, it is our expectation that the majority of Drop-Off Sites will be Retail Pharmacies. Appendix B-2 represents a list of confirmed Mail-Back Distribution Sites. Appendix B-4 represents a list of potential Mail-Back Distribution Sites.

It is Inmar's intention not to duplicate any locations for Kiosk placement with existing plan operators. If necessary and upon plan approval, Inmar will coordinate with existing plan operators on how to manage a Kiosk at the same location. Inmar will not approach sites that are currently being serviced by other approved Plan Operators until minimum convenience goals have been met. All Covered Drugs will be accepted at Drop-off Sites operated by more than one Stewardship Plan.

The below maps represent coverage of San Mateo County, upon plan approval, by the current list of confirmed Drop-off Sites. Each map includes both Drop-off Sites as well as Mail-Back Distribution Sites. The maps serve to demonstrate coverage at both a 5 mile radius and 15 mile radius from the Drop-off Sites.

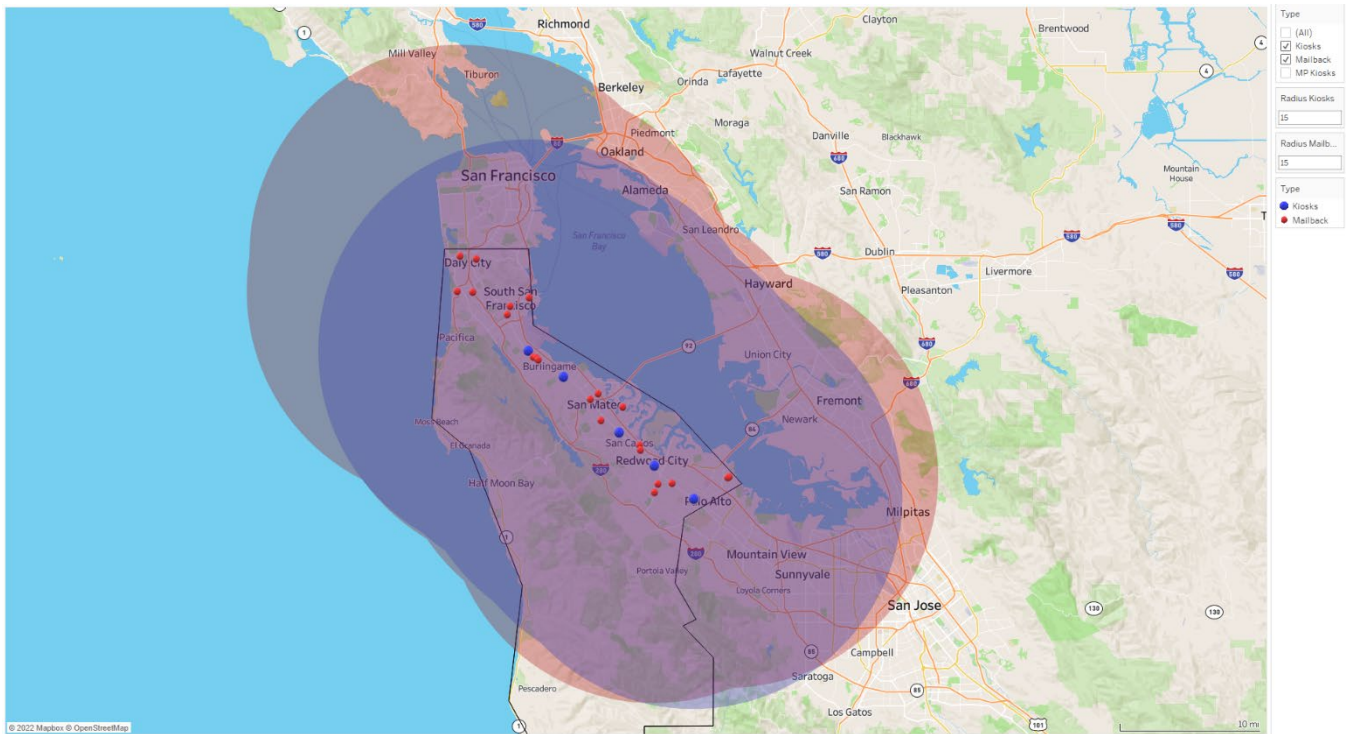
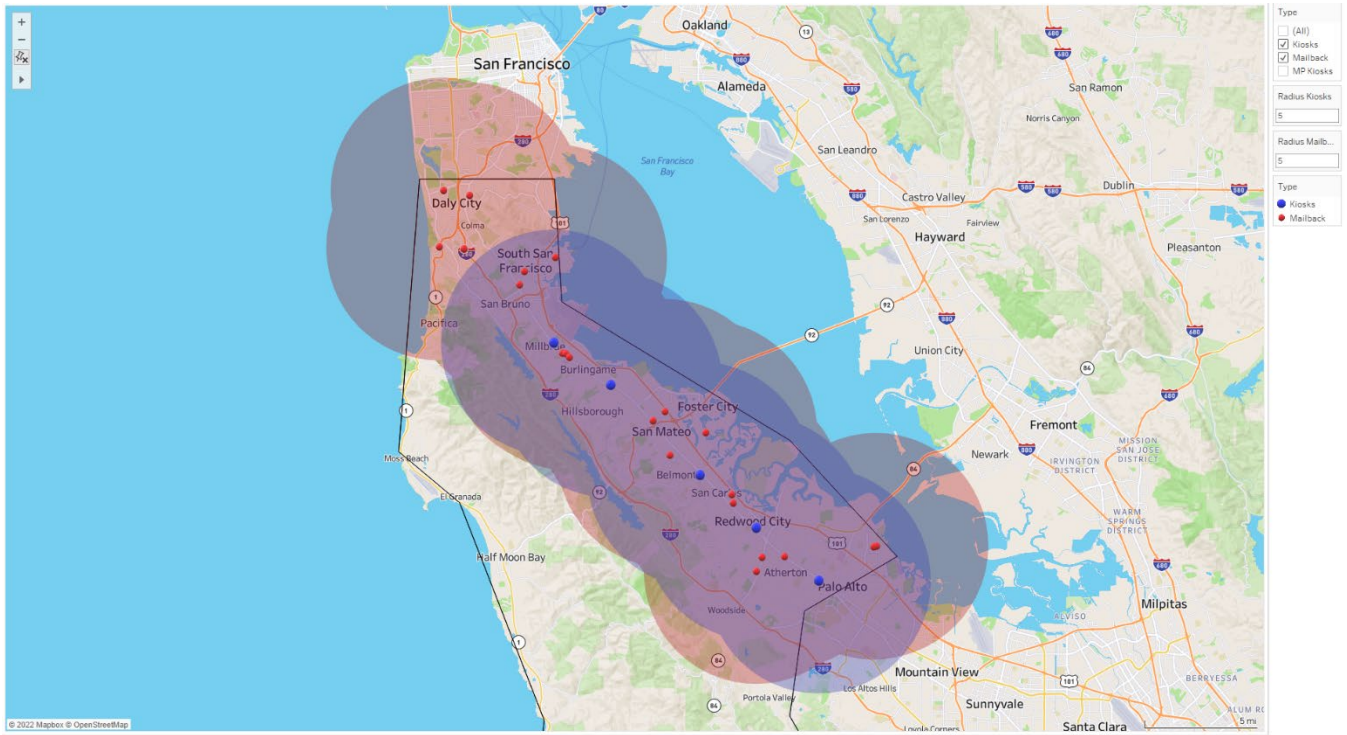

B. Kiosk Specifications and Design

Ordinance 04736 Section 4.116.040(b)

Ordinance 04736 Section 4.116.050(d)

Inmar's Kiosk is made in the USA and designed for excellence. Produced from 16 gauge cold-rolled steel, and with an easy-to-use, Americans with Disabilities Act (ADA)-compliant drop-box design, Residents can easily drop unused medications through the Drop-door and into the shippable Container with Inner Liner inside. The Container is a 275lb rated box with a 6 mil, DEA-compliant liner.

There are several unique features that enhance the effectiveness and security of the Inmar Kiosk. For example, the top of the Kiosk is sloped, limiting the ability to stack items on top. In addition, the drop slot features an extended metal Drop-door that lowers into the Container to detect when product capacity is reached. When the Drop-door encounters resistance within the Kiosk, it is an indication that it is time to change the Container. This manual capacity indicator eliminates the need to change batteries and/or sacrifice the location of the Kiosk to be in proximity to an electrical outlet. Lastly, the Container access door is reversible to allow for convenient placement in any appropriate location in the Pharmacy.

Per DEA requirements, the Kiosk must be installed in the line of sight of the Pharmacy and bolted to the floor or a permanent fixture. The Inmar Kiosk has pre-drilled holes in the bottom for easier installation. It also features a 4-point locking system with steel projections in two center locations and the top and bottom of the door that are activated when locked for strengthened security. Top and bottom deadbolt locations are hidden from the outside to prevent break-ins.

The Inmar Kiosk will have signage that communicates what is and is not allowed to be placed inside. The signage will also feature a website and toll-free telephone number so users of the program can ask questions and find more information. Inmar will work with the Environmental Health Division of the County of San Mateo to design signage that meets the needs and requirements of the program. See Appendix C for examples of signage.

Inmar's DEA- and ADA-compliant Kiosk is sent to the Authorized Collector along with enough supplies for 3 returns. Supplies include:

- Pre-addressed, pre-paid serialized Containers
- Serialized Inner Liners to protect against puncture and provide a liquid barrier
- Easy-to-use, serialized zip ties to seal each Inner Liner compliantly
- Absorbent pad for placement in the bottom of the Inner Liner bag

Pick-Up and Disposal

For the safe on-site removal of contents and servicing of drug take-back Kiosks, Inmar abides by the DEA regulations in 21 CFR 1300 et al.

Inmar will work with each Authorized Collector to develop a collection program schedule that works specifically for their location - either an on-site or self-service option as outlined below.

With either of the service models outlined below, the focus will be on each Authorized Collector to

develop a program that works specifically for their location.

A support help desk will also be established that will assist the Authorized Collectors with set-up, administration and operation of the Kiosk at the collection sites.

Standard Self-Service Returns

Inmar will train Authorized Collectors to service the Containers on their own to allow for expedited servicing as desired. The steps to service a Container are fast, efficient, and DEA-compliant. Inmar will provide Authorized Collectors with training materials including step-by-step instructions for tracking, sealing, replacing, and shipping collection Containers. See attached Steps to Start, FAQs, and Installation Instructions provided Appendix D.

Optional On-Site Pick-Up Service

Inmar may offer on-site service for the collection, replacement, and shipping of full Containers. On-site service will be provided by a qualified service representative. To remain compliant with the DEA, the Authorized Collector will need two employees to oversee the service process with the Kiosk.

Auto-Replenishment of Kiosk Supplies

Auto-replenishment of the supplies needed to collect and transport returned medications is provided in “kits” of three. Each kit includes: pre-labeled and pre-paid cardboard box Containers, liquid barriers, and serialized, puncture-resistant Inner Liners. Upon receipt of the second return within the kit, Inmar automatically ships another kit with a set of three Containers/supplies. This auto-replenishment reduces the amount of inventory maintained at the collection site while maintaining sufficient replacement supplies to keep the Kiosk continuously operable.



Figure 1: Kiosk Supply Auto-Replenishment Kit

Optional On-Site Pick-Up Service

Inmar will offer on-site service for the collection, replacement and shipping of full Containers. This all-inclusive program removes the burden for the Authorized Collector and the Pharmacy staff.

Inmar will initiate standard service intervals for each collection site. Once a pattern of usage has been established, the service schedule will be adjusted with the agreement of the Authorized Collector to provide the best overall service with minimal interruption.

Inmar will work with the Authorized Collector to adjust the schedule based on utilization of the receptacle.

The “Pre-Scheduled Service Event” will include:

- Observation of the condition of the receptacle upon arrival
- Notification to the Pharmacy personnel of arrival
- Coordination of 2 Pharmacy Employees to witness change out of receptacle supplies
- Removal, packaging, and documentation of the Container from the receptacle
- Replenishment of new supplies for renewed operation
- General clean-up and wipe down of receptacle
- Notation of Container serial number removed, and serial number installed along with signatures by 2 Pharmacy Employees (witnesses)
- Removal of full Container to be placed behind the Pharmacy counter to await FedEx pick up.
- Final signature from Pharmacy personnel of completion of Service Event.

*At no point will the Authorized Collector have to store the packaged Container for longer than 48 hours after calling FedEx.

Regardless of the service model selected, Inmar has a long standing contractual relationship with FedEx and therefore has multiple internal and external contacts. Inmar’s procurement and operations teams have direct relationships with personnel at FedEx corporate office. Should an issue arise with the standard 48 hour service level agreement, these contacts will be leveraged daily for mitigation of further issues as well as any needed general support. Detailed FedEx contact information can be found in Section V.

Inmar will periodically monitor all Container FedEx shipment tracking numbers from Pharmacy locations to the designated reverse distributor as designated in Section V.

Our training with both the retail Pharmacy technicians and Inmar technicians include documentation which details the steps required to schedule FedEx pickups of the full Containers. Inmar conveys this training both in written and oral format.

For locations where Inmar technicians aren’t regularly servicing Kiosks, Inmar has established several processes for issues to be mitigated. Aside from visual inspection when locking and unlocking the Kiosk for use during Pharmacy hours, Pharmacy staff are provided with the following resources should they experience issues with the Kiosk:

- Email the take-back@inmar.com inbox which is monitored by a large team of full

time workers and issues can be quickly triaged and handled.

Inmar has a team of full time staff members dedicated to the program that will regularly visit Kiosk locations to review and audit locations for program compliance.

C. Mail-Back Envelope Program

Ordinance 04736 Section 4.116.050(b)(5)

As required by Ordinance 04736 Section 4.116.050(b)(5), Inmar will provide prepaid and pre-addressed Mailers, free of charge, to all Residents including disabled or homebound County Residents. Mailers will be provided at Mail-Back Distribution Sites, and will also be available directly from Inmar via the program website and toll-free phone number.

Inmar will offer Mail-Back Services at multiple retail locations throughout the County. In locations where Inmar needs to offer Mail-Back Services to supplement the requirements for the convenience standard, our plan is simple and easily repeated. Unless otherwise requested by Drop-Off Sites, we will distribute Mailers only at locations that are non-Kiosk locations.

Once a location has been accepted as a Mail-Back Distribution Site, Inmar will send a stack of prepaid, pre-addressed Mailers to that location as a Mail-Back Starter Kit. Mailers will accept all Unwanted Covered Drugs, including pills, creams and liquids, and schedule II-V controlled substances. However, inhalers and Auto-injectors will require the use of different mailback packages (described below) and will not be included in the Starter Kit. The Starter Kit will include 20 Mailers sent to each location. Inmar will track the unique identifier for all Mailers sent to each location for fulfillment and logistical purposes. Inmar will add a visual reorder trigger in the box of Mailers. Once the location gets to the reorder trigger in the box, the visual reorder trigger will instruct the location to email Inmar for another kit. This service model ensures that there is no 'down time' at the site for Mailers. If a location begins to use a larger number of Mailers, the number of fulfilled envelopes sent to that location will be increased.

Inmar is committed to providing all Pharmacies an option to supply their customers with information regarding Mail-Back Service options. Inmar will provide Pharmacies with small cards that can be handed out to County Residents that may need access to this service. The card will instruct them to either call or visit the Program website to locate the nearest Kiosk or request a Mailer. Additionally, we will reach out to Pharmacies filling prescriptions by mail to include the cards for the same options.

Additionally, County Residents will be able to request up to three Mailers at a time via the Plan website or toll-free phone number. County Residents will receive the Mailer(s) no later than 10 business days from the date of request.

Both the Standard Mail-Back Envelope and Inhaler Mail-Back Envelope will meet DEA rule requirements under

§ 1317.70(c):

- Preaddressed, postage paid
- Nondescript, and do not indicate what may be inside
- Waterproof, tamper-evident, tear-resistant, and sealable

- Contain a unique ID number that allows for tracking
- Include instructions for the user that indicate the process for mailing the package, substances that can be sent, notice that packages can only be mailed in the US customs territory, and notice that the only packages provided by the Authorized Collector will be accepted
- No personally-identifiable information will be required

Both Envelopes are white in color with a gray interior and are 7" x 10". The Envelopes include a 3" perforated lip security seal. They are distributed by our third party contractor 123 Compliant Logistics, Inc.

A sample Standard Mail-Back Envelope is shown below.

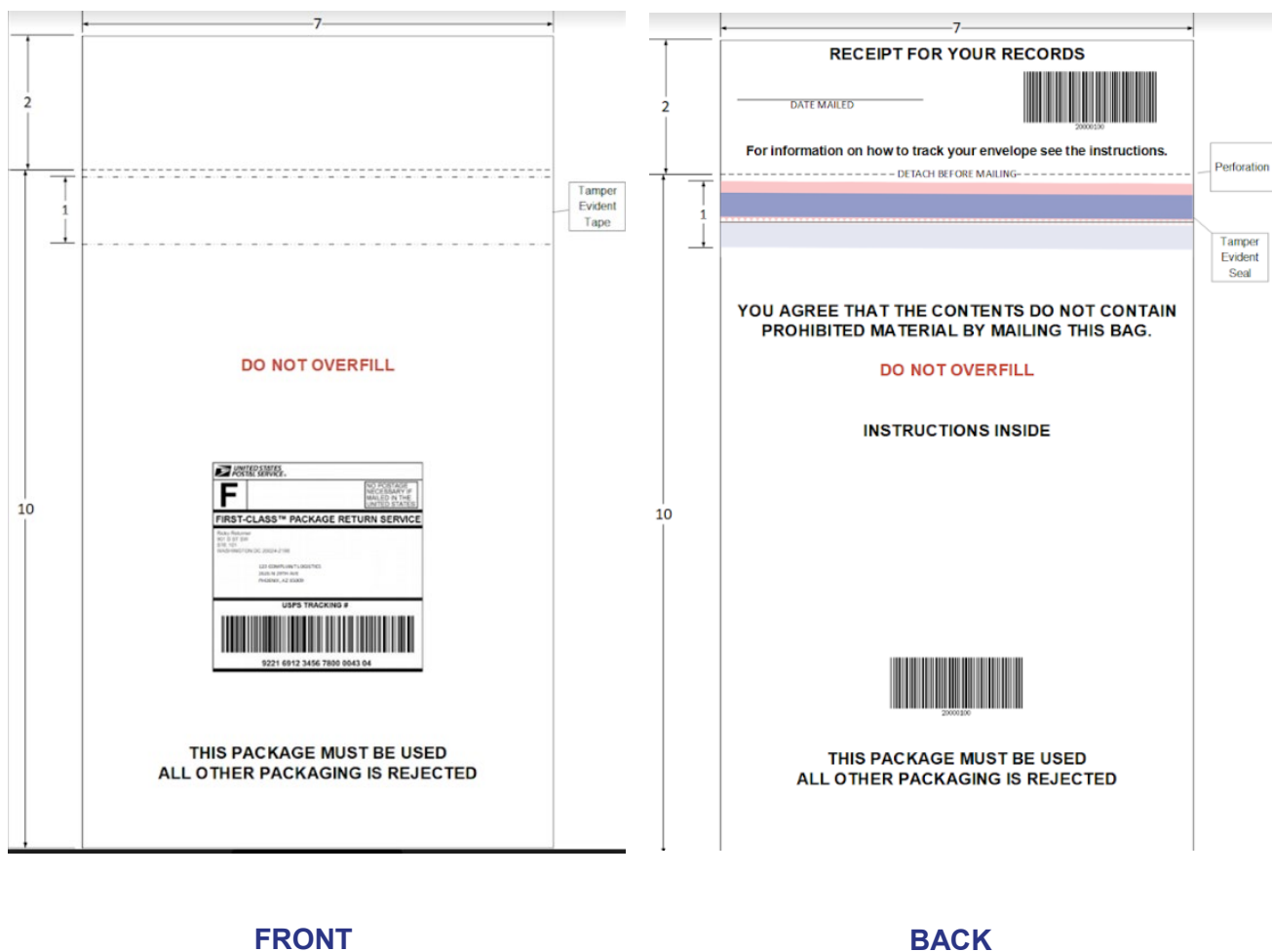

Figure 2: Sample Standard Mail-Back Envelope

Sample Inhaler Envelope

County Residents will be able to request one Inhaler Envelope at a time via the Plan website or toll-free number. County Residents will receive the Inhaler Envelopes no later than 10 business days from the date of request.

A sample Inhaler Mail-Back Envelope is shown below:

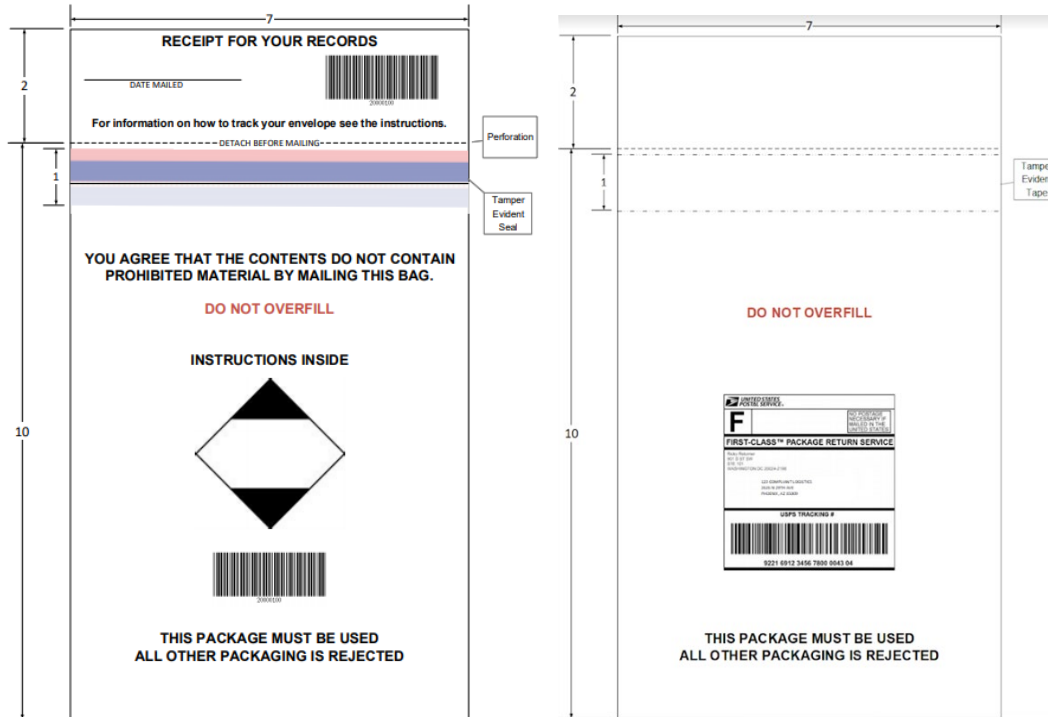

Figure 3: Sample Inhaler Mail-Back Envelope

Sample Auto Injector Mail-Back Package

County Residents will also be able request up to three Auto-injector Mail-back Packages at a time via the Plan website or toll-free phone number. County Residents will receive the Auto-injector Mail-back Package(s) no later than 10 business days from the date of request. Auto-injector Mail-Back Packages will meet all DOT requirements and will be fulfilled by 123 Compliant Logistics, LLC, or other Service Providers as listed. See below for specifications and sample package.

Specifications	
Access	Petals
Dimensions (in.)	7.5 x 3.6 x 3.6 in.
Color	Red
Lid Type	Hinge Cap
Liquid Absorbing Pad	Product has liquid absorbing pad
Universal Biohaz Sym	Product has universal biohaz symbol
Volume (L)	1.4 qt



Figure 4: Sample Auto Injector Mail-Back Package

Mail-Back Instructions

Mail-Back instructions to County Residents for all types of Mailers are provided in Appendix C.

Mail-Back Envelope Tracking

Mailers distributed by authorized Mail-Back Distribution Sites will be tracked in a method similar to the Kiosk collection Containers. Mailers will have a unique, serialized identification number. Once the Mailer arrives at the destruction facility, the serial number will be noted before final disposition.

Mailers distributed directly to consumers via request from the website or toll-free telephone number will be tracked by Inmar when sent to consumers and tracked at the destruction facility when they are returned.

This tracking process will allow Inmar to report the number of Mailers distributed and returned in the Annual Reporting provided to the Department, as required.

D. Collection Events

Pursuant to Section 4.116.050(b)(1) of the Ordinance, Inmar will hold periodic Collection Events where service convenience goals cannot be achieved due to a lack of Drop-off Sites per Supervisorial District. Collection Events will be held in accordance with the applicable regulations and protocols of the Drug Enforcement Administration of the United States Department of Justice. Below is a description for planning, hosting, staffing, and promoting Collection Events.

Location Planning and Scheduling

Locations of Collection Events will be determined based on the Supervisorial Districts that are most in need while taking into consideration their access to Kiosk and Mail-back Distribution sites. Once the area of need is identified, Inmar will explore locations where it is feasible to host a Collection Event. Most often this will be at a Law Enforcement Agency (LEA) or a satellite LEA location nearest the target area. However, Inmar has relationships with many other organizations that may be interested in hosting a Collection Event. We may determine these locations to be even more convenient for Residents if they are places that the population is already visiting on a regular basis or can accommodate unique situations such as drive-through collection during peak flu and virus seasons. Additionally, Inmar will consider the willingness or availability for LEA's to provide oversight at the selected location. Inmar will ensure any selected locations meet all applicable laws and regulations.

Event Staffing and Oversight

In compliance with DEA 1317.65(a)-(b), Inmar will ensure that at least one Law Enforcement Agency personnel is present at each Collection Event. LEA's will be responsible for maintaining any records of removal, storage, or destruction of the controlled substances collected in a manner that is consistent with that agency's recordkeeping requirements for illicit controlled substances evidence. In addition, any controlled substances collected at collection events will be stored and transferred for destruction in a manner that prevents the diversion of these substances.

Inmar will provide adequate staffing and resources to assist LEAs with logistics, coordination and/or other needs during the event. It will be Inmar's responsibility to coordinate with the City and LEAs to ensure compliance with all applicable laws and regulations. Inmar will work with the designated LEA to ensure that all material collected is placed in compliant Containers and any material that does not meet legal requirements is rejected.

Execution Procedures

As required by DEA 1317.65, Law Enforcement Officers employed and authorized by the LEA will maintain control and custody of the collected substances from the time the substances are collected from the County Resident until secure transfer, storage, or destruction of the controlled substances has occurred.

Inmar will ensure that only Residents and persons entitled to dispose of a Resident's decedent's property in lawful possession of a controlled substance in Schedule II-V may transfer these substances to law enforcement during the Collection Event. No other person will handle the controlled substances at any time.

At the conclusion of Collection Events, Inmar will work with LEAs to ensure that the collected materials are properly weighed, packaged, and shipped to Inmar's designated destruction partner in compliance with all applicable laws. As is standard practice for Kiosk returns under this Plan, Containers will be tracked via their unique identifiers from shipment location to the designated destruction facility.

Inmar will make certain that LEAs keep a record of the following information after the transfer of controlled substances as a result of any Collection Events:

- Unique identification number of the sealed Inner Liner transferred
- Size of the sealed Inner Liner transferred (e.g., 35-gallon)
- Name, address, and registration number of the reverse distributor to whom the controlled substances were transferred

Collection Event Promotion

Inmar will work with the local law enforcement agency or other designated location on any advertisement, promotion, set-up and tear down of the event and community engagement. Inmar will provide promotion for the Collection Event, including local advertising, LEA (or other location organization), social media, and press releases to local news outlets.

Collection Event Reporting

Pursuant to Section 4.116.090(a), Inmar will include in the Annual Report the following information:

- Date and location of each collection event held
- The amount, by weight, of drugs collected at each collection event
- The total amount, by weight, of drugs disposed of by collection events

E. Safety, Security and Patient Privacy

Ordinance 04736 Section 4.116.040(e)

Ordinance 04736 Section 4.116.050(b)(2)

Inmar provides significant training to our participating Authorized Collectors and strictly follows the DEA guidelines for the proper handling of the Kiosks and Inner Liners. This begins with the proper training of the Authorized Collector in the compliant operation of the Kiosks and proper preparation, removal, and packaging of the Container. It also involves the training of the Inmar staff that may come into contact with the full Container to ensure proper handling. Inmar is very strict in our compliance to the DEA guidelines.

According to the DEA - As provided in §§ 1317.60(c) and 1317.70(f), Inner Liners shall be sealed immediately upon removal from the permanent outer Container; sealed Inner Liners and returned Mailers shall not be opened, x-rayed, analyzed, or otherwise penetrated. Accordingly, their contents shall not be sorted or inventoried subsequent to being placed into a Kiosk or Mailer. To clarify this, § 1317.75(c) was modified to add the prohibition against individually handling substances after they have been deposited into a Kiosk.



Inmar has a long history of serving both commercial and government clients with stringent compliance standards such as the protection of Protected Health Information (PHI) and HIPAA.

Inmar has a long history of serving both commercial and government clients with stringent program requirements. For example, Inmar's Pharmacy applications manage Protected Healthcare Information (PHI) and are HIPAA compliant. Additionally, as part of Inmar's Rx Returns (reverse distribution) business, we work very closely with regulators to implement compliant procedures covering the DEA, Boards of Pharmacy, Environmental Protection Agency, and other tangential regulatory entities. Data protection, privacy and adherence to applicable regulations are the foundation of Inmar service capabilities.

Any and all patient information on drug packaging and Mailers will be promptly destroyed in accordance with Section 4.116.050(b)(3).

F. Collector

Ordinance 04736 Section 4.116.050(b)(3)

Ordinance 04736 Section 4.116.050(b)(4)

Inmar will give preference to Retail Pharmacies and Law Enforcement Agencies as Drop-off Sites and will ensure they are able to meet the requirements within three months of their offer to participate. Appendix B-3 contains a list of potential locations which would utilize a Kiosk as the Collection Method upon becoming a Collector. Inmar can also provide Drop-off Sites at hospital locations.

G. Drop Off Sites

Ordinance 04736 Section 4.116.050(b)(4)

Ordinance 04736 Section 4.116.050(c-d)

Pursuant to Ordinance 04736 Section 4.116.050(d) Inmar will accept Covered Drugs from Residents during all hours that the retail Pharmacy, law enforcement agency, or other Authorized Collector is normally open for business.

All Drop-off Sites will utilize secure Kiosks as described in section (d). Per DEA requirements, the Kiosk must be installed in the line of sight of the Pharmacy and bolted to the floor or a permanent fixture. The Inmar Kiosk has pre-drilled holes in the bottom for easier installation. It also features a 4-point locking system with steel projections in two center locations and the top and bottom of the door that are activated when locked for strengthened security. Top and bottom deadbolt locations are hidden from the outside to prevent break-ins.

In the unlikely event that more than one Stewardship Plan operates a Drop-off Site at a particular location, Inmar agrees that each Drop-off Site will accept all Covered Drugs. Additionally, in compliance with Ordinance 04736 Section 4.116.050(c), Inmar will coordinate with existing Program Operators, and any future Program Operators, to operate San Mateo County's single County-owned Pharmacy Kiosk. This may include an agreement for one of the approved Program Operators to independently operate the Kiosk.

V. Handling and Disposal

Ordinance 04736 Section 4.116.040(c)

Ordinance 04736 Section 4.116.070

Kiosk Containers will be sent using Inmar’s DOT Special Permit #20499, from the Authorized Collector via FedEx to Inmar’s third party contractor, 123 Compliant Logistics, LLC, a licensed DEA Reverse Distributor-Collector. Inmar has secured backup Service Providers as listed on the table below which may be used to provide these services. All Mailers will be sent via USPS to 123 Compliant Logistics. 123 Compliant Logistics will record the following information upon receipt of every individual Container and Mailer:

- Date received
- Serialized barcode label information
- Tracking information (Kiosk Containers only)
- Weight
- Date transported to disposal facility
- Disposal Date
- Manifest number (if applicable)

All information recorded will be transferred back to Inmar on a daily basis as part of the electronic raw data file via SSH File Transfer Protocol (SFTP). Any discrepancies observed at 123 Compliant Logistics will be recorded on discrepancy reports to prompt any corrective action.

123 Compliant Logistics operates in full compliance with DEA § 1317.75(c) which prohibits handling substances after they have been deposited into a collection Kiosk.

All product shipped directly to 123 Compliant Logistics will be transported using their contracted, licensed hazardous waste transporter, TransChem Environmental to the appropriate disposal facility to be incinerated quickly, securely, efficiently and in accordance with all DEA requirements. 123 Compliant Logistics will be responsible for all DEA Form 41 record keeping requirements. Please refer to the table below for the contracted disposal locations.

In reference to Ordinance 04736 Section 4.116.070(a), all Collectors, transporters and waste disposal facilities will operate under and comply with all applicable local, state and federal laws and guidelines surrounding the transportation and disposal of Unwanted Covered Drugs. Additionally, service related to the collection, transport and disposal of Unwanted Covered Drugs will be provided to Authorized Collectors and Residents at no cost. Contact information and registration information is listed in the table below.

Company Name	Contact Information	Registration Information	Type of Service
123 Compliant Logistics, LLC 2626 N 29th Ave Phoenix, AZ 85009	Rory Buske 602-612-4140	DEA Reverse Distributor-Collector: R90571364	Reverse Distributor – Kiosk Containers
Indianapolis Resource Recovery Facility in Indiana, operating as Covanta Indianapolis, Inc. 2515 S. Holt Street, Suite 200 Indianapolis, IN 46241	Scott Willard 317-719-6397	DEA Reverse Distributor-Collector RC0561628 USPS-040A19	Back-up vendor for reverse distribution – All Covered Drugs (Mail-back Packages & Packaged Containers from Authorized Collectors)

Covanta Manheim dba Chesapeake Waste Solutions 190 Shellyland Rd, Manheim PA 17545	Ken Wilson 717-653-8882	DEA Registration No. RC0322595	Back-up vendor for reverse distribution – All Covered Drugs (Mail-back Packages & Packaged Containers from Authorized Collectors)
Ross Incineration Services 36790 Giles Road, Grafton, OH 44044	Chris Fada 440-748-5800	EPA ID No. OHD048415665	Hazardous Waste Incinerator Covered Drugs-Kiosks & Mailers
Clean Harbors Aragonite 11600N. Aptus Rd. Aragonite, UT94029	Michael Marlow 435-884-8100	EPA ID: UTD981552177	Hazardous Waste Incinerator Covered Drugs - Kiosks & Mailers
Clean Harbors El Dorado, LLC 309 American Circle El Dorado, AR 71730	Dan Roblee 870-863-7173	EPA ID: ARD069748192	Hazardous Waste Incinerator Covered Drugs - Kiosks & all Mail-back packages
Veolia ES Technical Solutions, L.L.C 7665 Highway 73 Port Arthur, TX 77640	David Michaelis 281-216-9618	EPA ID: TXD000838896	Hazardous Waste Incinerator Covered Drugs – Kiosks & all Mail-back packages
TransChem Environmental 542 East 27 th Street Tucson, AZ 85713	520-829-5651	DOT Registration: 052119550060B Hazardous Materials Safety Permit: US-1341480-AZ-HMSP	Hazardous Waste Transporter
Ross Transportation Services, Inc. 36790 Giles Road Grafton, OH 44044	Chris Fada 440-748-5800	PADEP Registration: PA- HC0283	Hazardous Waste Transporter – All Unwanted Covered Drugs
FedEx	Eric Stillson 800-469-9993		Common Carrier – Kiosk Containers
USPS	Jackie Purcell 919-501-9394		Common Carrier – All Mail-back packages

VI. Policies and Procedures

Ordinance 04736 Section 4.116.040(d)

Inmar operates Kiosks across 49 States and the District of Columbia as part of its operations today and maintains compliance with all federal and state laws and regulations. Upon approval to act as a Stewardship Organization, Inmar will ensure that it acts in compliance with all applicable laws, rules, and regulations as specified by the program requirements and require by contract where applicable that all collectors, transporters, and waste disposal facilities operate under and comply with all applicable federal and state laws, rules, and guidelines including, but not limited to, The Controlled Substances Act, 21 USC SS 801-971 and 21 CFR SS 1317; United States Department of Transportation Hazardous Materials Regulation, 49 CFR parts 100-185; All applicable San Mateo County Rules and Regulations.

The DEA Rule defines Authorized Collectors as Law Enforcement Agencies and additionally as Retail Pharmacies, reverse distributors, hospitals or clinics with onsite Pharmacies and certain other entities that are registered with DEA as an Authorized Collector.

Inmar requires a signed agreement with retail locations ensuring their commitment to compliant operation of the Kiosk and shipping of contents in compliance to the DEA regulations. A refusal to sign the

agreement or comply with the DEA regulations would be a reason why a retailer could be excluded from the San Mateo County Stewardship Plan.

Documentation and Tracking

Collection Containers and Inner Liners will have a serialized identification number to enable tracking at all stages of the return process illustrated below.



Figure 5: Return Process Tracking

Kiosk tracking is well-documented as evidenced by the Inmar serialization tracking form that is included in full as Appendix D and referenced below. This form must be completed and witnessed by two authorized collection site employees, which assures compliance and safety across the program, and internally by both the Stewardship Organization and the Authorized Collector.

Name of Collecting Pharmacy		Address of Collecting Pharmacy		Collecting Pharmacy DEA #:			
SERIAL NUMBERS	Date Received by (1 Signatures)	Date In Use (2 Signatures)	Date Removed (2 Signatures)	Date Shipped (2 Signatures)	Size of Liner	Address of Reverse Distributor/Disposal Site	Reverse Distributor/Disposal Site DEA #
Ex: 32587	4/26/19 John Jones	4/26/19 John Jones Sally Smith	5/26/19 John Jones Sally Smith	5/27/19 John Jones Sally Smith	Ex: 18 Gallon	1515 S Holt Road Indianapolis, IN 46241	Ex: 123456

Figure 6: Inmar Serialization Tracking Form

The purpose of this form is to document the use of the serialized Inner Liner throughout the collection process and to help the Authorized Collector meet record-keeping requirements. Inmar will require each Authorized Collector to understand and comply with all federal, state, and local regulatory requirements pertaining to take-back pharmaceuticals applicable at the Authorized Collector's registered location.

The serial numbers, date received, and signatures of the authorized Pharmacy Employees must be completed upon receipt of the Container and Inner Liner. As illustrated above, the date-in-use is to be completed with authorized Pharmacy Employee signatures upon installation of the Kiosk. The date the

Container and Inner Liner are removed from the Kiosk is also to be noted with signatures. Finally, the date the Container and Inner Liner are shipped is to be noted with authorized signatures.

Authorized Collectors must maintain a copy of the completed form, and other records as applicable, on file at the Authorized Collector's registered location for at least three years.

Mailers are sent via USPS to 123 Compliant Logistics or alternative Service Provider. County Residents utilizing Mail-back Services place their Unwanted Covered Drugs inside the Mailer, remove the perforated portion (which contains the tracking ID for the main package) and mail the package. While in transit, Residents can track the package to ensure that it has arrived at 123 Compliant Logistics.

County Residents can track their own packages, and should they notice any issues, they can contact Inmar Intelligence to indicate that their package was lost in transit. Inmar Intelligence will also periodically monitor Mail-Back Packages being sent via USPS to 123 Compliant Logistics for potential issues. If any issues are identified, Inmar will immediately notify 123 Compliant Logistics and begin to leverage our partnerships with USPS to initiate an investigation. Findings from any incidents of USPS Mailer issues will be provided in the annual report.

Transport

The Authorized Collector will properly seal, store securely, and arrange for pickup of the sealed Inner Liner and its contents from the registered location in a manner consistent with DEA regulations. The Container will include a pre-addressed and prepaid shipping label. The common carrier representative will take possession of the liner and deliver the liner to an approved destruction facility for witnessed incineration.

Disposal

Once the Container and Inner Liner arrives at the destruction facility, the serial number will be noted before final disposition.

This tracking process will allow Inmar to report the number of Containers and Inner Liners distributed and returned in the reporting provided to San Mateo County, as required.

Compliance with Applicable Laws

Inmar operates across 49 states and the District of Columbia and maintains compliance with all federal and state rules and laws. Upon approval to act as a "Stewardship Organization," Inmar will ensure that it acts in compliance with all applicable laws, rules, and regulations as specified by the program requirements and require by contract where applicable that vendors and collection sites are also compliant with all laws, regulations and legal requirements.

Inmar's drug Kiosks are DEA- and ADA-compliant and provide environmental protection from unwanted drug residue. The units are equipped with a four-point locking system with hidden steel deadbolts that are activated when locked for strengthened security. They contain pre-drilled holes at the bottom of the unit for easy installation to securely bolt them to the floor in each approved collection site. The internal Container and supplies protect against puncture and provide a liquid barrier to prevent seepage and/or spillage.

Inmar's Training Materials, found in Appendix D, aid collection sites in proper drug Kiosk installation, which helps optimize the security of the unit. The Training Materials also include information on Kiosk operation, inner Container materials assembly and placement, regulated shipping instructions, program FAQs, and serialization tracking. All of these inclusions maximize the safety and security of any person involved in the program at the collector level.

Procedures for Unplanned Emergencies

Inmar is ready and willing to assist Authorized Collectors should there be any unplanned emergency such as a natural disaster or any type of security incident. Personnel will respond to assist only when the situation is deemed safe for travel or safe for personnel to be on-site due to current natural or unplanned events. Should the integrity and security of Drop-off Sites be compromised, Inmar will work with the Authorized Collector to develop a strategy to ensure that the Kiosks and sites are safe and secure.

Should an Authorized Collector need to report an incident which would require special intervention, the Collector can contact Inmar via the approved Program Website or Toll-free Phone Number. Authorized Collectors are also given access to a direct line of communication with Inmar where these types of incidents are able to be reported. Inmar will work to mitigate any potential issue with its Authorized Collectors.

Inmar maintains a policy and trains Authorized Collectors on how to respond to varying levels of emergencies which includes contacting emergency services or Inmar directly.

In the case of an unplanned event such as a natural disaster or a fire, Inmar will notify the Director in writing no later than 10 business days after learning of the event. Should the event be labeled catastrophic, as defined by FEMA, (https://www.fema.gov/pdf/emergency/nrf/nrf_CatastrophicIncidentAnnex.pdf) Inmar will notify the DEQ as soon as reasonably possible. Any safety or security incidents will be reported in the annual report as required by the Ordinance section 4.116.090(a)(8).

Updated information on the status of Drop-off Sites will always remain updated on the Program Website.

Procedures for Maintenance Requests

Inmar provides maintenance at least once per quarter or as requested. Drop-off Sites are able to email a monitored email inbox which is operated by a team who triage Authorized Collector requests. Should a Kiosk require maintenance outside of the quarterly service schedule, the maintenance request will be resolved within three business days of the initial request.

- Requests can be made by emailing take-back@inmar.com inbox, which is monitored by a team and issues can be quickly triaged and handled. This inbox is the quickest and most effective way for Inmar to respond to any issues with Kiosks.
- Authorized Collectors can also call 1-800-350-0396, option 5 for urgent issues

Inmar will track requests received through the public or Drop-off Sites, indicating the nature of the request and the response resolution time. These records will be included in the Annual Report as part of the records of safety and security problems and outreach activities.

VII. Public Education Effort and Promotion Strategy

Ordinance 04736 Section 4.116.040(f)

Ordinance 04736 Section 4.116.060

A. Promotion

Ordinance 04736 Section 4.116.060(a)(1)

Inmar will execute a comprehensive and measurable public outreach strategy to drive awareness of the Program and maximize participation as required by Section 4.116.060 of the San Mateo County Safe Drug Disposal Ordinance. In addition to preventative education, Inmar's strategy is designed to ensure that where and how to return Covered Drugs is widely understood by Residents, pharmacists, Retail Pharmacies, health care facilities and providers, veterinarians, and veterinary hospitals. It is Inmar's goal to reach a 50% saturation rate after 2 years for the promotion of San Mateo County's population. This will be measured by a question in the biennial survey which requests participants to identify whether certain promotional activities have reached them.

A leader in the promotions space for nearly 40 years, Inmar has a unique set of core capabilities relative to other prospective program operators, specifically in consumer marketing and activation. Thus, in addition to traditional outreach methods (signage, written materials, etc.), Inmar is able to drive participation among Residents with modern, high-impact tactics such as influencer marketing and targeted media.

The individual components of Inmar's public outreach strategy are detailed below. Across all tactics, key messages will include, but are not be limited to, the following:

- Encourage safe storage of drugs in the home (especially around children and teens)
- Dangers of drug misuse (i.e., not taking medicines as prescribed)
- Discourage improper disposal of drugs (e.g., flushing or solid waste collection)
- Arrival of a safe drug take-back solution with instructions for how to locate and participate
- Consumer Drug Take-Back Day promotion

A single program website will ensure that all Residents can easily identify, understand, and access the collection services provided by Inmar and other program operators. The other approved Plan Operator will not coordinate with Inmar until Inmar is approved to operate in the County. Upon plan approval coordination efforts will include providing a single website and toll-free telephone number to access information about collection services for all approved Programs. As of the date of submission of this Plan the approved Program Operator has begun to draft terms of coordination. See section H for more information and a plan for the single system of promotion.

B. Standardized Instructions

Ordinance 04736 Section 4.116.060(a)(2)

As required in the Ordinance 04736 Section 4.116.060(a)(2), Inmar will coordinate with the existing approved Program Operator to develop a single system of promotion to include standardized instructions for County Residents. Additionally, Inmar provides Authorized Collectors with easy to understand and standardized instructions explaining how to use the collection Kiosk. The educational materials will be distributed to audiences such as LEAs, Pharmacies, healthcare providers and systems, local government agencies and community organizations. Materials and outreach channels

include:

1. Website and toll-free phone number
2. Educational Materials
 - i. Educational brochure for Residents
 1. Including information on what types of Unwanted Covered Drugs including inhalers and Auto-injectors are accepted
 - ii. Training materials for Authorized Collectors
 1. Container Instructions
 2. Steps to Start Document
 3. Installation Reference Guide
 4. Serialization Tracker
3. Public Outreach

Sample educational materials for Residents are provided in Appendix C. Training material samples are provided in Appendix D.

Collection Receptacle Signage

As indicated previously, the current Program Operator will not coordinate with Inmar until Inmar is approved to operate in the County. However, Inmar is willing and able to assume the current instructions and design for Kiosks. Inmar has done this successfully in the past upon agreement from the current Program Operator and the execution of a licensing agreement. Inmar is committed to providing Kiosks that are readily recognizable by all Residents and that provide clear graphical instructions in required languages. Please see Appendix C for sample images of the Kiosk and disposal instructions.

C. Website and Toll-Free Number

Ordinance 04736 Section 4.116.060(a)(3)

Website

The current County approved Program Operator operates the Program's website. Inmar agrees to use the existing website in coordination with the other approved Program Operator should they agree to that solution in their terms of coordination. A single shared website falls under the coordination that the approved Program Operator will not discuss until Inmar's approval. As such, upon approval, Inmar is committed to working with any approved Stewardship Plan Operator(s) as required to determine a fair and equitable method in jointly meeting the requirements under the Ordinance.

Alternatively, Inmar can provide a mobile-optimized website, appropriately translated into English, Spanish, Chinese and Tagalog, which will publicize collection options and educate Residents on proper disposal practices. Inmar will use enhanced search engine optimization to ensure easy location and access.

Specifically, the website would:

- Leverage Inmar's collaboration with Google Maps to allow Residents to find the nearest collection site or mail-back distribution site via an interactive map. The list of locations will be updated monthly to ensure accuracy.
- Allow Residents to request prepaid return Mailers.

Retailers or Pharmacies interested in participating in the Program will be able to request more information through the website.

Toll-Free Phone Number

The current County approved Program Operator operates the toll-free phone number 844-633-7765 in the required languages. Inmar agrees to use the existing toll-free phone number in coordination with any other approved Program Operator(s). Upon approval, Inmar is committed to working with any approved Program Operator(s) as required to determine a fair and equitable method in jointly meeting the requirements under the Ordinance.

Alternatively Inmar can operate a multi-lingual, (English, Spanish, Chinese and Tagalog), toll-free call center that interested parties can call to learn more about the Program, and best practices for disposal of Unwanted Covered Drugs. The call center is operated with live operators and will be staffed with a third party service to assist with live translation in the required languages. All operators are trained to assist and answer questions related to any and all questions related to the Stewardship Plan operation including but not limited to Authorized Collector Kiosk support and service requests. County Residents will also be able to request information about the nearest Drop-off Site or Mail-Back Distribution Site, or request that a prepaid Mailer is sent to them. Upon Plan approval Inmar will coordinate with existing Program Operators on a unified, single toll-free phone number for Residents. We have provided a call center map below which demonstrates call flows through the call center.

CALL CENTER

Call Center Script: "Thank you for contacting the Consumer Drug Take Back Center. My name is _____. How May I Help you?"

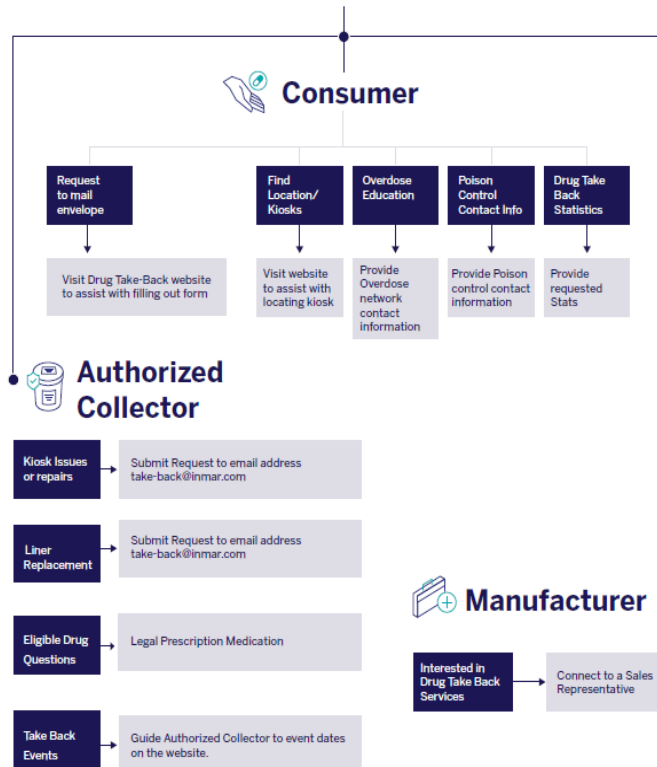

Figure 7: Call Center Flow

D. Educational Materials

Educational Brochure for Residents

Inmar will provide educational material to Pharmacies, health care facilities, veterinary facilities, and other interested parties annually and upon request. The educational brochure will be provided in Tagalog, Spanish, Chinese, and English. Inmar will document each stakeholder provided educational material and include this information in our annual report.

Educational material will:

- Educate County Residents about the appropriate use, storage, and disposal of Unwanted Medicine
- Provide County Residents with clear steps to properly manage the disposal of their Unwanted Medicine including following instructions found on the medicine label, use of Kiosk Drop-Off Sites,
- Instructions on requesting a Mailer
- Provide best-practices for in-home disposal where no disposal instructions are given on the drug labeling.

All materials will be easily understandable by Residents with varying levels of English proficiency and will leverage explanatory graphics to aid in comprehension.

Please see Appendix C for example materials.

Training Materials for Authorized Collectors

Inmar provides Authorized Collectors with easy to understand and standardized instructions explaining how to use the collection Kiosk. Training material provided to Authorized Collectors include:

1. FAQs
2. Container Instructions
3. Steps to Start Document – Including Kiosk Maintenance requests
4. Installation Reference Guide
5. Serialization Tracker

Marketing tool kits are shipped with initial Kiosk and Liner Kits however additional materials can be requested via email at take-back@inmar.com. Drop-Off Sites will also be routinely visited by Inmar staff to ensure they are adequately staffed and operating compliantly with the Plan.

Training material samples are provided in Appendix D. Note: Training materials will be updated upon Plan approval to include images reflecting appropriate PPE recommended for operating a Kiosk.

E. Public Outreach

Inmar's Stewardship Program will provide public outreach through the following channels:

Authorized Collector Marketing Support

Upon request, to drive awareness and participation at a local level, Inmar will provide individual

Authorized Collectors with a variety of marketing assets at no charge, including in-store signage, social media content kits, press release templates, and scripts for Pharmacy staff to let Residents know that they can safely dispose of their Covered Drugs at that location. Authorized Collectors will be able to request additional marketing materials through the provided contact information.

Please see Appendix E for example materials.

Social Influencer Marketing

The 2016 acquisition of Collective Bias gave Inmar the ability to execute robust, data-driven social influencer marketing programs that activate shoppers and patients alike. On average, Inmar executes approximately 500 such programs annually.

Inmar has a curated network of more than 12,000 highly-vetted influencers who are experts at creating authentic, compelling content that can drive awareness and inspire participation among Residents. Inmar utilizes sophisticated influencer selection, data-driven content distribution, and audience re-engagement tactics to ensure that content is hyper-relevant and that the Residents receiving the content are the ones most inclined to take action.

Inmar proposes to provide the following:

- 4 influencer programs per year, 1 per quarter
- 2 Social media posts per month on Instagram and Facebook
 - Content can focus on an array of topical themes, however, based on the Program requirements Inmar's recommendation would be one, or a combination of, the following:
 - Tips for safe storage of medications in the home prior to disposal
 - Education about the implications of improper drug disposal
 - Promotion of the drug take-back program, including directions on where and how to participate

Social Content Ads and Targeted Social Media

Inmar's expert paid media team actively monitors social influencer content for the highest performers. The most engaging content is promoted across social platforms as well as the Google ad network to amplify the message around drug take-back to a targeted cohort of Residents.

Inmar executed a social influencer marketing program promoting drug take-back in April of 2019 which yielded exceptional results (see Sub-Section 7 for more information on impact measurement and reporting). The campaign generated 11.4MM impressions, but, more importantly, the posts themselves were highly engaging. The average click-through-rate (CTR) was 4.5% (a historical CTR benchmark in this category is 1.5 - 2.0%) and users spent an average of one minute and eight seconds on each post. Both metrics suggest users found the content compelling and useful. Please see Appendix E for sample social influencer content. We also invite you to view some of the top performing posts linked below:

- [*Life in Check Consumer Drug Take-Back receptacle | National Prescription Drug Take-Back Day by Meagan Harrell*](#)
- [*5 Easy Tips to Declutter Your Closet + Safe Medication Disposal by Valerie Clement*](#)
- [*How to Dispose of Unused Medications Safely - Mom Always Knows by Elizabeth Hurt*](#)

Impact Measurement

In accordance with Section 4.116.090(a)(9) of the Ordinance, Inmar will provide a description of outreach initiatives in its annual report, but also aims to provide more frequent and actionable reporting on the impact of such initiatives.

With specific regard to social influencer marketing and targeted media, Inmar's measurement tools and philosophies have continuously set the industry standard with their emphasis on transparency and quantifiability over vanity metrics and theoretical explanations.

All paid and organic activity is measured using the industry's most powerful analytics suite to capture authenticated results. Reporting will include:

- Platform and Third-party verified Impression and Content View reporting
- Engagement breakdown by social platform, including Time on Content
- Thumbnail links to all influencer content, and performance metrics for individual influencer posts

F. Biennial Survey

Ordinance 04736 Section 4.116.060(a)(4)

Inmar will coordinate with existing Program Operators to conduct a biennial survey of San Mateo County Residents as well as pharmacists, veterinarians and health professionals who interact with patients on use of medicines after the first full year of operation of the Stewardship Plan. The aim of the survey questions will be to measure the percent awareness of the Stewardship Plan, assess to what extent Drop-off Sites and other Collection Methods are convenient and easy to use, and assess knowledge and attitudes about risks of abuse, poisonings, and overdoses from prescription and non-prescription drugs used in the home. Inmar will coordinate with existing Program Operators to ensure that we do not overlap on communication channels and duplicate survey respondent results.

Draft survey questions will be submitted to the Director for review and comment at least 30 days prior to the initiation of the survey. Results of the survey will be reported to the Director and made available to the public on the website required in subsection (a)(3) within 90 calendar days of the end of the survey period. The privacy of all survey respondents will be maintained.

G. Language Translation

Ordinance 04736 Section 4.116.060(b)

All outreach methods will be translated into English, Spanish, Chinese and Tagalog.

H. Multiple Stewardship Plans

Ordinance 04736 Section 4.116.060(c)

Inmar will work with the Director to develop a single system of promotion for all Stewardship Plans when multiple plans exist. All collateral pieces will have consistent messaging to Residents in coordination with other Program Operators. As of the date of submission of this Plan, the approved Program Operator is drafting terms of coordination for Inmar to review. Once these terms are agreed

upon, Inmar will work with the existing Program Operator to provide the Director with a mutually agreed upon document, outlining the principles of coordination, specifying the required elements of the single-system of promotion.

VIII. Short-term and Long-term Goals

Ordinance 04736 Section 4.116.040(g)

	Short-Term (180 days from approval)	Long-Term (181+ days from approval)
Collection	<ul style="list-style-type: none"> • Initiate program operation • Place 51 Drop-off Sites (1 per 20,000 Residents spread across the 5 per Supervisorial Districts) preferably at Retail Pharmacies, hospitals and clinics with on-site Pharmacies, and Law Enforcement Agencies <ul style="list-style-type: none"> ○ Inmar estimates collection of 20 lbs. per quarter per Drop-off Site on average • Establish Mail-back Service in areas that are underserved by collection Drop-off Sites (500 lbs. per year) 	<ul style="list-style-type: none"> • Increase collection by 5% per year
Education & Promotion	<ul style="list-style-type: none"> • Finalize a plan of coordination with other approved Program Operator on a unified website, phone number and other promotional materials • Establish a baseline of percentage of Residents reached through social media and other targeted media outreach • Provide training material to each Authorized Collector • Educational brochures will be provided at Drop-Off Sites annually in quantities of 100 in English and 50 in the other required languages and upon request of the Collector. 	<ul style="list-style-type: none"> • Reach 25% of the population through plan media outreach tactics by the end of year 1. Reach and sustain a 50% saturation rate for the media plan outreach tactics by the end of year 2 and beyond. Continue public awareness and outreach campaign as described in Section VII of Plan with a sustained reach of 50% of San Mateo Residents. • All Authorized Collectors have been properly trained on collection and disposal as indicated by a reduction to baseline of messages received by Inmar from Authorized Collectors about training and knowledge gaps.

IX. Additional Plan Considerations

Ordinance 04736 Section 4.116.040(h)

Existing Providers of Pharmaceutical Waste Services

To the extent that existing providers of pharmaceutical waste are already in operation, Inmar will determine if coordinating efforts creates efficiencies for the County and improves convenient and equitable access for County Residents.

Furthermore, to the extent that there are other Stewardship Organizations, Inmar will seek to coordinate its activities with said programs within 6 months after Inmar’s stewardship program is approved. Inmar’s Consumer Drug Take-Back website will ensure that all consumers can easily identify, understand, and access the collection services provided by Inmar and other Stewardship Organizations. Coordination efforts will include providing a single website and toll-free telephone number to access information about collection services for all approved programs.

Inmar will work with the current approved Plan Operator and submit to the Department a mutually agreed upon document outlining the terms of coordination. Such document will outline a single system of coordination to include the following elements: Kiosk Design, Kiosk Signage, Mailer instructional insert(s) or flyer(s), Mail-Back Distribution Site signage, Resident-facing Website, Resident Facing Toll-Free Phone Number, Promotion/Media to include standardized instructions to County Residents and to the local health care community and pharmacies.

Package Separation & Recycling

DEA § 317.75(c) prohibits handling substances after they have been deposited into a collection Kiosk. For this reason, Inmar is unable to separate and recycle drug packaging. However, Inmar can execute educational programs, as outlined in Section VII, to encourage County Residents to separate Unwanted Covered Drugs from their packaging and recycle the packaging prior to disposal.

Even though regulations prevent us from recycling drug packaging, Inmar still has a vested interest in reducing waste and improving our environment. Through our Rx Returns and related business lines, Inmar has saved over 20,000 barrels of oil, recovered over 11,000 megawatts of clean energy and powered over 900 homes in just the past two years alone. We will continue to look for opportunities to expand our eco-friendly efforts in San Mateo County.



Inmar Energy Metrics

Megawatts of Clean Energy Recovered:

2017 = 5,436
2018 = 5,643

Barrels of Oil Saved:

2017 = 9,896
2018 = 10,270

Homes Powered for a Year:

2017 = 482
2018 = 495

X. Administrative and Operational Costs and Fees

Pursuant to Section 4.116.030(e)(6), Inmar’s plan includes multiple Producers who pay all administrative and operational costs and fees associated with its Stewardship Plan. Each Producer pays a fee for services performed by Inmar. This fee is based on several factors including market share of Covered Drugs throughout the County. Below is a list of costs that are covered by Producers as part of their fee to Inmar:

- Collection and transportation supplies for each Drop-off Site;
- Acquisition of all secure collection bins for Drop-off Sites;
- Ongoing maintenance or replacement of secure collection bins, as requested by collectors;
- Prepaid, pre-addressed Mailers provided to disabled and/or home-bound County Residents;
- Transportation of all collected Covered Drugs to final disposal, including costs of law enforcement escort if necessary;
- Environmentally sound disposal of all collected Covered Drugs under Section 4.116.070 of this chapter;
- Program promotion under Section 4.116.060 of this chapter; and
- Costs related to any review of a product Stewardship Plan for purposes of obtaining compliance with the California Environmental Quality Act (Cal. Pub. Res. Code § 21000, et seq.).

Retail Pharmacies are not expected to incur any costs for participation however any staff or staff duties performed by the retailer in conjunction with the plan are not costs covered by the Producers or Inmar.

XI. Reporting

Ordinance 04736 Section 4.116.090

Within six months after the end of the first 12-month period of operation, and annually thereafter for a period covering January 1 – December 31, Inmar will submit a report describing the program's activities during the previous reporting period. The report will include:

- (1) A list of participating Producers
- (2) The amount by weight of Covered Drugs collected, including the amount by weight from each Collection Method used
- (3) A list of Drop-off Sites
- (4) The number of Mailers provided for disabled and/or home-bound County Residents
- (5) The locations where Mailers were provided, as applicable
- (6) The dates and locations of Collection Events held, as applicable
- (7) The transporters used and the disposal facility or facilities used for all Covered Drugs
- (8) Whether any safety or security problems occurred during collection, transportation or disposal of Unwanted Covered Drugs during the reporting period and, if so, what changes have or will be made to policies, procedures or tracking mechanisms to alleviate the problem and to improve safety and security in the future
- (9) A description of the public education, outreach and evaluation activities implemented during the reporting period
- (10) A description of how collected packaging was recycled to the extent feasible, including the recycling facility or facilities used
- (11) A summary of the Stewardship Program's goals, the degree of success in meeting those goals in the past year, and, if any goals have not been met, what effort will be made to achieve the goals in the next year
- (12) The total expenditures of the stewardship program during the reporting period.

XII. Prior Approval for Plan Changes

In accordance with Section 4.116.120 of the Ordinance, Inmar will comply with the following:

- Changes that substantively alter plan operations, including, but not limited to, changes to participating Manufacturers, Collection Methods, achievement of the service convenience goal, policies and procedures for handling Unwanted Covered Drugs, or education and promotion methods or disposal facilities shall be approved in writing by the Director before the changes are implemented.
- Proposed changes to an approved Stewardship Plan shall be submitted within six months upon notice from the Director of a change to the population of a Supervisorial District as described in Section 4.116.050(b)(1).
- Proposed changes that substantively alter plan operations as described above shall be submitted to the Director in writing at least 30 days before the change is scheduled to occur and be accompanied by the review fee in accordance with Section 4.116.150 of the Ordinance.
- Inmar shall notify the Director at least 15 days before implementing any changes to Drop-off Site locations, methods for scheduling and locating periodic Collection Events, or methods for distributing prepaid, preaddressed Mailers, that do not substantively alter achievement of the service convenience goal under Section 4.116.050(b)(1) of the Ordinance, or other changes that do not substantively alter plan operations under Section 4.116.120(a).

Inmar acknowledges that advanced determination may be sought from the Director on whether a proposed change would be deemed to substantively alter plan operations.

XIV. APPENDIX

A. Participating Producers	37
B-1. Authorized Collectors Offering to Participate in the Program	44
B-2. Mail-Back Distribution Sites Offering to Participate in the Program	44
B-3. Potential Drop-Off Sites Contacted by Inmar	45
B-4. Potential Mail-Back Distribution Sites Contacted by Inmar	46
C. Kiosk Signage, Mail-Back Inserts and Educational Brochure	65
D. Training Material	71
E. Public Outreach Material	88
F. Applicable Permits and Licenses	93

Appendix A: Participating Producers

Producer Name	Contact Name	Title	Address	Email	Phone	Website
AAA Pharmaceutical, Inc.	Tejash Sheth	Vice President	681 Main Street Lumberton, NJ 08048	tsheth@aaapharm.com	609-288-6060 x 202	https://aaapharm.com/cms/
Adare Pharmaceuticals	Babu Lad	Global Head of Regulatory Affairs/Executive Director	1200 Lenox Drive, Suite 100, Lawrenceville, NJ 08648	Email: Babu.Lad@adareps.com	Phone: 609-376-1719	https://www.adarepharmasolutions.com/
Advagen Pharma Ltd	Narendra Borkar	President	666 Plainsboro Rd, Suite 605, Plainsboro, NJ 08536	Email: Narendra.Borkar@advagenpharma.com	Phone: 609-269-8128	https://www.advagenpharma.com/
Alcon Vision, LLC	Herman Blakley	Director, Health Safety Environment	6201 South Freeway, TA625, Fort Worth, TX 76134	Email: herman.blakley@alcon.com	Phone: 610-670-3824	https://www.alcon.com/
Alexso, Inc.	Farbod Melamed	Pharmacist, Regulatory Compliance	2317 Cotner Ave, Los Angeles, CA 90064	Email: Farbod@alexso.com	Phone: 310-282-8086	https://www.alexso.com/
Alkermes, Inc.	Jim Delaney	Senior Director, National Channel Accounts	852 Winter Street, Waltham, Massachusetts 02451	Email: James.Delaney@alkermes.com	Phone: 516-826-1785	https://www.alkermes.com/
ANDA, Inc	Emily Hall	Sr Mgr, Regulatory Compliance	2915 Weston Road, Weston, FL 33331	Email: emily.hall@andanet.com	Phone: 800-331-2632 Ext. 74579	https://www.andanet.com/
Anda Pharmaceuticals, Inc	Emily Hall	Sr Mgr, Regulatory Compliance	8644 Polk Lane Olive Branch, Mississippi 38654	Email: emily.hall@andanet.com	Phone: 800-331-2632 Ext. 74579	https://www.andanet.com/
Apnar Pharma, LP	Vandan Patel	IT Manager	4820 Lanier Road, Chino, CA 91710	Email: vandan.patel@apnarpharma.com	Phone: 844-283-9825	www.apnarpharma.com
Archis Pharma, LLC	Vivin Lukose	Director	15 Corporate Place South, Suite 108, Piscataway, NJ 08854	Email: vmlukose@rkpharmainc.com	Phone: 732-640-4351	http://www.archispharma.com/
Ascend Laboratories	Hindy Schiff	Vice President Regulatory Affairs/Compliance	339 Jefferson Road, Suite 101, Parsippany, NJ 07054 USA	Email: HSchiff@ascendlaboratories.com	Phone: 908.612.3079	https://www.ascendlaboratories.com/
ASO LLC	Federico Juliao	Sr. Director of Regulatory Affairs	300 Sarasota Center Blvd, Sarasota, FL 34240	Email: fjuliao@asocorp.com	Phone: 941-379-0300	https://www.asocorp.com/
Avet Pharmaceuticals Inc.	Chris Heckler	Senior Director, Commercial Operations	1 Tower Center Boulevard, Suite 1700,	Email: Chris.Heckler@avetpharma.com	Phone: 732-429-1000	https://avetpharma.com/

			East Brunswick, NJ 08816			
Bell Pharmaceuticals, Inc	Betty Jo Lorenz	VP, Quality & Regulatory Affairs	200 W. Beaver St. Belle Plaine, MN 56011	Email: Bettyjo@bellpharm.com	Phone: 952-873-2288	https://bellpharm.com/
Biocodex, Inc.	Scott Koppang	Senior Director, Pharmaceutical Affairs, Chief Compliance Officer	1850 Gateway Drive, Suite 175 San Mateo, CA 94404	Email: s.koppang@biocodex.com	Phone: 650-466-6935	https://www.biocodex.com/en/
Blairex Laboratories, Inc	Jeff Legston	President	1600 Brian Dr, Columbus, IN 47201	Email: jlogston@blairex.com	Phone: 812-378-1864	https://blairex.com/
Camber Pharmaceuticals, Inc.	Ron Cerminaro	Director, Commercial Strategy and Operations	1031 Centennial Ave., Piscataway, NJ 08854	Email: rcerminaro@camberpharma.com	Phone: 732.529.0430	https://www.camberpharma.com/
Canton Laboratories, LLC	Jack Melesh	Director of Finance	1015 Nine North Dr, Suite 200, Alpharetta, GA 30004	Email: jmelesh@cantonlabs.com	Phone: 678-867-2900	http://www.cantonlabs.com/
Carlsbad Technology, Inc	Sally Ver Vynck	Account Executive	5922 Farnsworth Court, Carlsbad, CA 92008	Email: sally.vervynck@carlsbadtech.com	Phone: 858-260-9198	http://carlsbadtech.com/
Celltrion USA, Inc.	Edwin Baras	Director Head of Supply Chain	One Evertrust Plaza, suite 1207, Jersey City, NJ 07302	Email: Edwin.Baras@celltrion.com	Phone: 201-600-9241	Website - pending
Dr. Reddy's Laboratories Inc.	Suet Horhota	Manager, Finance & Commercial Operations	107 College Road East, Princeton, NJ 08540	Email: shorhota@drreddys.com	Phone: (609) 806-3961	https://www.drreddys.com/
Facet Medical Technologies, LLC	James R. Bonds	Director Regulatory Affairs	3900 N Commerce Dr., Atlanta, GA 30344	Email: jbonds@facetmed.com	Phone: 770-590-6462	https://facetmed.com
Florida Pharmaceutical Products, LLC	Gina Campbell	SVP Commercial Operations	6111 Broken Sound Parkway NW, Suite 160 Boca Raton, FL 33487	Email: gcampbell@flpharmaproducts.com	Phone: 561-609-3240	https://flpharmaproducts.com/
Formulation Technology, Inc.	Marie Porter	Director of Operations	571 Armstrong Way, Oakdale, CA 95361	Email: marie@formulationtech.com	Phone: 209-847-0331	www.formulationtech.com
Fosun Pharma USA, Inc	Huong Nguyen	General Counsel	104 Carnegie Center Drive, Suite 204, Princeton, NJ 08540	Email: huong.nguyen@fosunpharmausa.com	Phone: 408-200-9891	https://www.fosunpharma.com/en/
Genomma Lab USA, Inc	Bradley N. Johnson, Ph.D.	Director, US Quality & Regulatory Affairs	3737 Buffalo Speedway, Houston, TX 77098	Email: johnson.bradley@genommalab.com	Phone: 713-907-6570	https://www.genommalab.com/en/
Gensco Laboratories, LLC	Paul M. Zimmerman, MD	CEO	8550 NW 33rd St, Suite 200, Doral, FL 33122	Email: info@genscolabs.com	Phone: 855-743-6726	https://genscopharma.com/

Global Diabetic Distributors, Inc.	Steve Hamilton	President	P.O. Box 881982, Port St Lucie, FL 34988; 6657 Southwest Silver Wolf Dr, Palm City, FL 34990	Email: steveh@gmphs.com	Phone: 866-949-8884	Website - Pending
Granules Pharmaceuticals, Inc.	Tanvi Mane	Regulatory Affairs Associate	3701 Concorde Parkway, Chantilly, VA 20151	Email: Tanvi.Mane@granulespharma.com	Phone: 857 415 0784	https://granulesindia.com/granules-usa/
Hetero Labs Limited	Ron Cerminaro	Director, Commercial Strategy and Operations	1031 Centennial Ave., Piscataway, NJ 08854	Email: rcerminaro@camberpharma.com	Phone: 732.529.0430	https://www.camberpharma.com/
Hikma Pharmaceuticals USA Inc.	Heather S. Patrick	Sr. Analyst, Legal Affairs	200 Connell Drive, 4th Floor, Berkeley Heights, NJ 07922	Email: hpatrick@hikma.com	Phone: 908.673.1030	https://www.hikma.com/home/
i3 Pharmaceuticals, LLC	Kartik Bhagat	Director, Finance & Operations Support	200 Park Avenue, Warminster, PA 18974	Email: kbhagat@i3pharmaceuticals.com	Phone: 215-443-7000	https://www.i3pharmaceuticals.com/
Intercept Pharmaceuticals, Inc.	Robert Satterfield	Executive Director, Quality Systems - Process & Compliance	305 Madison Avenue, Morristown, NJ 07960	Email: bob.satterfield@interceptpharma.com	Phone: 646-747-1000	https://www.interceptpharma.com/
KC Pharmaceuticals, Inc.	Efren M. Haas	Director of Quality	3215 Producer Way, Pomona, CA 91768	Email: ehaas@kc-ph.com	Phone: 909-598-9499 x 23	https://kc-ph.com/
Lannett Company Inc.	Michael Gankiewicz	Director DEA & Security	1101 C Avenue West, Seymour, IN 47274	Email: mgankiewicz@lannett.com	Phone: 215-333-9000	https://www.lannett.com/
Laser Pharmaceuticals, LLC	Jack Melesh	Controller	1015 Nine North Drive, Suite 400, Alpharetta, GA 30305	Email: jmelesh@laserpharmaceuticals.com	Phone: 770-754-9846	www.LaserPharmaceuticals.com
Leading Pharma, LLC	Mark V. Chirico	Senior Manager Government Reporting and Contracts	3 Oak Rd, Fairfield, NJ 07004	Email: MCHIRICO@LEADINGPHARMA.COM	Phone: 973-276-9600	https://www.leadingpharma.com/
Macleods Pharma Usa, Inc	Jasleen Gupta	Director PV/QA	103 College Road East, 2nd Floor, Princeton, NJ 08540	Email: jasleeng@macleodspharma.com	Phone: 609-269-5250	https://www.macleodspharma.com/usa/
Marnel Pharmaceuticals, LLC	Elizabeth Shuttleworth	Director of Operations	635 East Bay St, Bldg G, Charleston, SC 29403	Email: eshuttleworth@marnelpharmaceuticals.com	Phone: 888-850-2905	https://marnelpharmaceuticals.com/
McKeon Products, Inc.	Tamara Peters	Operations Manager	25460 Guenther,	Email: tamara@macksearplugs.com	Phone: 586-427-7200 ext 12	https://www.macksearplugs.com/

			Warren, MI 48091			
Medicure Pharma, Inc	Leanne Taylor	Compliance officer	116 Village Blvd., Suite 200, Princeton, New Jersey	Email: LTaylor@medicure.com	Phone: 1-888-435-2220	https://www.medicure.com/
Medsource Pharmaceuticals	Raissa Bola	Quality Control	22521 Avenida Empresa, Ste 109, Rancho Santa Margarita, CA 92688	Email: Orders@medsourcepharmaceuticals.com	Phone: 888-612-1965	http://medsourcepharmaceuticals.com/
Micro Labs USA, Inc	Gaurang Bhavsar, RAC	Associate Director - Regulatory Affairs	220 Davidson Ave, Suite 402, Somerset, NJ 08873	Email: gaurangbhavsar@microlabs.in	Phone: 908-484-7410	http://www.microlabsltd.com/
Mirum Pharmaceuticals	Mark Jones	Counsel	950 Tower Lane, Suite 1050, Foster City, CA 94404	Email: mark.jones@mirumpharma.com	Phone: 650-667-4085	https://mirumpharma.com/
Monarch PCM, LLC	Sam Rizkal	CEO/CFO	7333 Jack Newell Blvd, Suite 100, Fort Worth, TX 76118	Email: samr@monarchpcm.com	Phone: 682-708-6488 x 127	https://www.monarchpcm.com/
Navajo Manufacturing Company Inc.	Felix Morales	Quality Assurance Manager	601 W 50th Ave, Denver, CO 80216	Email: fmorales@navajoinc.com	Phone: 303-292-3090 Ext 8265	https://navajoinc.com/
Neogen	Luke Brithinee	Counsel - Commercial & Compliance	620 Leshler Place, Lansing, MI 48912	Email: lbrithinee@neogen.com	Phone: 313-670-8934	https://www.neogen.com/
Neurelis, Inc	Joe Duarte	VP, Commercial Operations	3430 Carmel Mountain Road, Suite 300, San Diego, CA 92121	Email: jduarte@neurelis.com	Phone: 858-251-2124	https://www.neurelis.com/
New American Therapeutics, Inc	Phil Thompson	Chief Operating Officer and General Counsel	300 Interpace Parkway, Morris Corporate Center I, Building C3, Parsippany, NJ 07054	Email: pthompson@newamericantx.com	Phone: 314-326-6645	https://newamericantx.com/
NextSource Biotechnology	Thomas Hunter	General Counsel, Chief Compliance Officer, Secretary	80 SW 8th Street, Suite 2660, Miami, FL 33130	Email: tomhunter@trisourcepharm.com	Phone: 855-672-2468	https://www.nextsourcepharma.com/
Nivagen Pharmaceuticals	Genevieve Stevens	Operations Director	3050 Fite Circle, Suite 100, Sacramento, CA 95827	Email: gstevens@nivagen.com	Phone: 916-364-1662	https://www.nivagen.com/
Noden Pharma DAC	Juliana Santos	Supply Chain Planner	D'Olier Chambers, 16A D'Olier Street, Dublin 2, Republic of Ireland	Email: jsantos@nodenpharma.com	Phone: +353 1 912 15 88 x 588	https://www.nodenpharma.com/

Novadoz Pharmaceuticals, LLC	Michael Clark	Director Sales Operations	20 DUKE ROAD, SUITE A, PISCATAWAY, NJ 08854-3714	Email:michael.clark@NovadozPharma.com	Phone:848-200-1910	http://novadozpharma.com/
Novugen Pharma (USA), LLC	Michael Clark	Senior Director, Commercial Operations, USA	100 Overlook Center, 2nd Floor, Princeton, NJ 08540	Email:michael.clark@novugen.com	Phone: 732-857-7766	https://www.novugen.com/
Oyster Point Pharma, Inc.	Lawrence Levey	Head of Manufacturing and Supply Chain	202 Carnegie Center, Princeton, NJ 08540	Email:llevey@oysterpointrx.com	Phone: 732-649-9022	www.oysterpointrx.com
ParaPRO, LLC	Bill Culpepper	President	11550 N Meridian St, Suite 290, Carmel, IN 46032-5505	Email: billc@parapro.com	Phone: 317.810.6201	https://www.parapro.com/
Pharma Supply, Inc	Loretta Henry	Compliance Coordinator	3361 Fairlane Farms Rd, Suite 5, Wellington, FL 33414	Email:lhenry@pharmasupply.com	Phone: 888-469-3579	https://advocatemeters.com/
PharmaEssentia USA Corporation	Jeremy Griffin	Director, Technical CMC Operations and Supply Chain Management	35 Corporate Dr, Suite 325, Burlington, MA 01803	Email:jeremy_griffin@pharmaessentia.com	Phone: 617-245-2200	www.pharmaessentia.com
Prasco Laboratories	Matt Pendley	Sr. Director of Finance	6125 Commerce Court, Mason, OH 45040	Email:m.pendley@prasco.com	Phone: 513-618-3333	https://www.prasco.com/
ProvePharm	Tania Tardif	Office Operations Supervisor	100 Springhouse Drive Suite 105, Colledgeville, PA 19426	Email:tania.tardif@provepharm.com	Phone: 610-601-8600	https://www.provepharm.com/en
Randob Labs, Ltd dba CrossingWell Consumer Health	Jessica Cole	Executive Assistant	Mailing Address: PO Box 440 Cornwall, NY 12518 ; Physical Address: 45 Quaker Ave, Suite 207, Cornwall, NY 12518	Email:jessica@randob.com	Phone: 845-534-2197	www.CrossingWell.com
RedHill Biopharma Inc.	Michelle Dague	Senior Director, Compliance	8041 Arco Corporate Dr, Suite 200, Raleigh, NC 27617	Email:mdague@redhillus.com	Phone: 540-406-7460	https://www.redhillbio.com/home/default.aspx
Reese Pharmaceutical Company	Nicholas Green	Pharmaceutical Chemist	10617 Frank Avenue, Cleveland, OH 44106	Email:nick.green@reesechemical.com	Phone: 216-231-6441	https://reesechemical.com/
Reliable 1 Laboratories, LLC	David Seltzer	CEO	99 West Hawthorne Ave, Suite 610,	Email:david.seltzer@reliable1labs.com	Phone: 516-341-0666	https://www.reliable1labs.com/

			Valley Stream, NY 11580			
Retractable Technologies, Inc.	Michele Larios	Vice President and General Counsel	511 Lobo Lane, Little Elm, TX 75068	Email: rtilegal@retractable.com	Phone: 972-294-1010	https://retractable.com/
Sato Pharmaceutical Co., Ltd.	Bruce Takano	General Manager	3625 Del Amo Blvd. Suite 228, Torrance, CA 90503	Email: stakano@sato-pharmausa.com	Phone: 310-787-1877	https://www.sato-pharmaceutical.com/
SDI USA, Inc. DBA Simple Diagnostics	Muhammad Arif	President, CEO	5208 Grand Avenue, Maspeth, NY 11378	Email: ma@simplediagnostics.com	Phone: 877-342-2385	https://simplediagnostics.com/
Sheffield Pharmaceutical, LLC	Anthony Sollima	CSO and EVP of Regulatory Affairs	170 Broad Street, New London, CT 06385	Email: anthony.sollima@sheffieldpharma.com	Phone: 860-442-4451 ext 2281	http://www.sheffieldpharma.com/
SK Life Science, Inc.	Meghan H. Szczech	Executive Director, Patient Services and Trade	461 From Road, 5th FL, Paramus, NJ 07652	Email: mszczech@sklsi.com	Phone: 908-432-6939	www.SKLifescienceinc.com
SOLA Pharmaceuticals	Tanna Varner	Regulatory Operations Specialist	655 Highlandia Dr, Baton Rouge, LA 70810	Email: tanna@solameds.us	Phone: 866-747-7365	https://www.solameds.us/
Somerset Pharma, LLC	Arun Menon	Chief Commercial Officer	300 Franklin Square Dr, Somerset, NJ 08873	Email: arun.menon@somersetpharma.com	Phone: 732-554-1100	https://somersepharma.com/
Strides Pharma Inc.	Michael Altamuro	SVP, Sales & Marketing (US)	1 Ram Ridge Rd, Chestnut Ridge, NY 10977	Email: mike.altamuro@stridesusa.com	Phone: 845-682-3251	https://www.strides.com/
Summers Laboratories, Inc.	Linda Czeiner	General Manager	103 GP Clement Drive, Collegeville PA 19426	Email: lindac@sumlab.com	Phone: 877-902-3490	https://www.sumlab.com/
Sun (Taro) Pharmaceutical Industries, Inc.	Rick Lewellyn	Assoc. Dir. Supply Chain	2 Independence Way, Princeton, NJ 08540	Email: Richard.lewellyn@taro.com	Phone 914-345-9001	https://www.taro.com/ ; https://sunpharma.com/
Time-Cap Laboratories, Inc.	James Carroll	Division Chief Financial Officer	7 Michael Ave, Farmingdale, NY 11735	Email: jcarroll@timecaplabs.com	Phone: 631-753-9090	https://www.timecaplabs.com/
TruPharma, LLC	John E. Mooney	President	4100 W Kennedy Blvd, Suite 220, Tampa, FL 33609	Email: jmooney@trupharma.com	Phone: 312-953-2600	https://www.trupharma.com/
Ultimed, Inc.	Sarah Hanssen	Vice President Sales and Marketing	350 Highway 7, Suite 100, Excelsior, MN 55331	Email: s.hanssen@ultimedinc.com	Phone: 858-349-5906	https://www.ultimedinc.com/
Unichem Pharmaceuticals (USA), INC.	Kartik M. Keertikar	Senior Manager, Regulatory Affairs	One Tower Center Boulevard, Suite 2200, East Brunswick, NJ 08816	Email: kkeertikar@unichemusa.com	Phone: 732-253-5954	https://www.unichemusa.com/

Upsher-Smith Laboratories, LLC	Jennifer Graham	Corporate Paralegal - Compliance Specialist	6701 Evenstad Drive, Maple Grove, MN 55369	Email: Jennifer.Graham@upsher-smith.com	Phone: 763-315-2000	https://www.upsher-smith.com/
Urovant Sciences, Inc.	Ray Wong	Exec. Director, Medical Communications & Information	5281 California Ave, Suite 100, Irvine, CA 92617	Email: ray.wong@urovant.com	Phone: 949-508-1724	https://urovant.com/
Westminster Pharmaceuticals, LLC	Adrienne Fink	Financial Controller	3450 Buschwood Park Dr, Suite 110, Tampa, FL 33618	Email:finance@wprx.com	Phone:727-300-1376	https://www.wprx.com/
XL Care Pharmaceuticals, Inc	Ron Cerminaro	Director, Commercial Strategy and Operations	400 S. Technology Drive, Central Islip, New York 11722	Email: rcerminaro@camberpharma.com	Phone: 732.529.0430	https://www.camberpharma.com/

Appendix B-1: Authorized Collectors Offering to Participate in the Program

Site Name	Site Address	Site City	Site Zip	District
SAFEWAY PHARMACY #1547	1450 HOWARD AVE	BURLINGAME	94010	1
SAFEWAY PHARMACY #2878	525 EL CAMINO REAL	MILLBRAE	94030	1
SAFEWAY PHARMACY #1138	1100 EL CAMINO REAL	BELMONT	94002	3
SAFEWAY PHARMACY #2719	525 EL CAMINO REAL	MENLO PARK	94025	3
SAFEWAY PHARMACY #0305	1071 EL CAMINO REAL	REDWOOD CITY	94063	4

Appendix B-2: Mail-Back Distribution Sites Offering to Participate in the Program

STORE NAME	STORE ADDRESS	STORE CITY	Store Zip	DISTRICT #
LUCKY #748	1322 EL CAMINO REAL	SAN BRUNO	94066	1
ANCHOR DRUGS	161 SOUTH SPRUCE AVENUE	SOUTH SAN FRANCISCO	94080	1
DR. LAWRENCE L. CHAO - SAN MATEO OFFICE	1750 EL CAMINO REAL, SUITE 301	BURLINGAME	94010	1
MINDFUL HEALTH SOLUTIONS - BURLINGAME	1860 EL CAMINO REAL, SUITE 250	BURLINGAME	94010	1
LUCKY #726	45 MURCHISON DR	MILLBRAE	94030	1
APRIA - SOUTH SAN FRANCISCO LOCATION	480 CARLTON COURT	SOUTH SAN FRANCISCO	94080	1
COSTCO PHARMACY #422	451 SOUTH AIRPORT BLVD.	S. SAN FRANCISCO	94080	1
COSTCO PHARMACY #475	1600 EL CAMINO REAL	S. SAN FRANCISCO	94080	1
UCPC SAN MATEO PRIMARY CARE	1100 Park Place, Suite 100	SAN MATEO	94403	2
SAFEWAY 970	1655 EL CAMINO REAL	SAN MATEO	94402	2
ALEGRE HOME CARE - PENINSULA	1660 S. AMPHLETT BLVD., SUITE 128	SAN MATEO	94402	2
LUCKY #710	919 EDGEWATER BLVD	FOSTER CITY	94404	2
COSTCO PHARMACY #147	1001 METRO CENTER BLVD	FOSTER CITY	94404	2
LUCKY #749	1133 OLD COUNTY RD	SAN CARLOS	94070	3
CALIFORNIA SINUS CENTER	3351 EL CAMINO REAL SUITE 200	ATHERTON	94027	3
SLEEP QUEST - SAN CARLOS	981 INDUSTRIAL ROAD, SUITE B	SAN CARLOS	94070	3
RAVENSWOOD FAMILY DENISTRY	1807 BAY ROAD	EAST PALO ALTO	94303	4
RAVENSWOOD FAMILY HEALTH	1885 BAY ROAD	EAST PALO ALTO	94303	4

LUCKY #745	200 WOODSIDE PLAZA	REDWOOD CITY	94061	4
SAFEWAY 747	850 WOODSIDE RD	REDWOOD CITY	94061	4
COSTCO PHARMACY #1042	2300 MIDDLEFIELD ROAD	REDWOOD CITY	94063	4
BRIGHT LIFE	10 BELLCREST AVENUE	DALY CITY	94015	5
ACCLAIM HOME CARE INC. - DALEY CITY OFFICE	318 WEST LAKE CENTER, UNIT 227	DALEY CITY	94015	5
ANX HOSPICE CARE	455 HICKEY BLVD, SUITE 320	DALY CITY	94015	5
ANX HOME HEALTHCARE	455 HICKEY BLVD, SUITE 415	DALY CITY	94015	5
LUCKY #707	6843 MISSION ST	DALY CITY	94015	5

Appendix B-3: Potential Drop-Off Sites Contacted by Inmar

Company Name	Street	City	Postal Code	Contact Method
Broadway Pharmacy	1300 Broadway	Burlingame	94010-3426	Phone
Alphascript	420 Industrial Rd	San Carlos	94070	Phone
Anchor Drugs Iii	161 South Spruce Ave	South San Francisco	94080	Phone
Berkshire Pharmacy	11 Berkshire Ave	Redwood City	94063	Phone
Chinese Hospital Pharmacy	386 Gellert Blvd Suite A	Daly City	94015	Phone
Fair Oaks Community Pharmacy	2710 Middlefield Rd Ste 125	Redwood City	94063	Phone
Lpch Childrens Home Pharmacy	4600 Bohannon Dr Ste 105	Menlo Park	94025	Phone
Mariner Advanced Pharmacy Corp	43 East 3Rd Ave	San Mateo	94401	Phone
Pharmaca Integrative Pharmacy	871 Santa Cruz Ave	Menlo Park	94025	Phone
Pmc Pharmacy	843 Malcolm Rd	Burlingame	94010	Phone
Ravenswood Family Health Ctr Phcy	1885 Bay Road Suite A	East Palo Alto	94303	Phone
St Mary Prescription Pharmacy	401 S Canal St	South San Francisco	94080	Phone
Ted'S Village Pharmacy	29 W 25Th Ave	San Mateo	94403	Phone
Care4U Pharmacy	901 Campus Dr Ste 206	Daly City	94015	Phone

Half Moon Bay Pharmacy	40 Stone Pine Rd, Ste I	Half Moon Bay	94019	Phone
Seton Medical Center	1900 Sullivan Ave	Daly City	94015	Phone
Seventeen Fifty Med Ctr Phcy	1750 El Camino Real Ste 101	Burlingame	94010	Phone
Sunshine Center Pharmacy	1166 Mission Rd	South San Francisco	94080	Phone
A And O Peninsula Phcy	1828 El Camino Real Ste 104	Burlingame	94010	Phone
Nowrx	800 Burlway Rd	Burlingame	94010	Phone

Appendix B-4: Potential Mail-Back Distribution Sites Contacted by Inmar

Contact method for the following potential Mail-Back Distribution Sites was by phone. Many were left messages or are still in the discussion stage with Inmar.

Company Name	Street	City	Postal Code	Description
A Lucky Dog	205 De Anza Blvd	San Mateo	94402-3989	Farm animal boarding and care
A Pets Best Friend	Po Box 4514	San Mateo	94404-0514	Veterinary activities
Aba Physical Therapy Associates	1670 S Amphlett Blvd Ste 123	San Mateo	94402-2512	Hospital activities
Abc Pediatrics	50 S San Mateo Dr Ste 260	San Mateo	94401-3859	Specialists medical practice activities
Accrediting Commission	533 Airport Blvd Ste 200	Burlingame	94010-2009	Social work activities without accommodation for the elderly and disabled
Ace Casino Game Rentals	380 Swift Ave Ste 1	South San Francisco	94080-6232	Gambling and betting activities
Action Therapeutics	3 S Linden Ave	South San Francisco	94080-6407	Specialists medical practice activities
Active In-home Therapy	1111 Canada Rd	Woodside	94062-3508	Hospital activities
Active Life Medical Center, Inc.	1391 Woodside Rd Ste 200	Redwood City	94061-3574	Hospital activities
Acumen Llc	500 Airport Blvd Ste 365	Burlingame	94010-1936	Hospital activities
Acupuncture & Herbal Clinic	525 E 3rd Ave	San Mateo	94401-3302	Hospital activities

Acute Allergy Asthma	3301 El Camino Real Ste 101	Atherton	94027-3803	Hospital activities
Adolescent Counseling s	4000 Middlefield Rd Ste Fh	Palo Alto	94303-4761	Specialists medical practice activities
After Hour Pediatrics Urgent Care Clinic	210 Baldwin Ave	San Mateo	94401-3915	Specialists medical practice activities
After Midnight Inc.	3623 Glenwood Ave	Redwood City	94062-3031	Other residential care activities n.e.c.
After School Brittan Acres	873 Cordilleras Ave	San Carlos	94070-3731	Other residential care activities n.e.c.
Ageway	617 Veterans Blvd	Redwood City	94063-1496	Other residential care activities n.e.c.
Alborzi Orthodontics	235 N San Mateo Dr Ste 300	San Mateo	94401-2672	Dental practice activities
Allegro Dental Group Dmd	4585 Mission St	San Francisco	94112-2603	Dental practice activities
Allergy & Asthma Consultants	369 Main St	Redwood City	94063-1758	Hospital activities
Alma Heights Christian Academy	1295 Seville Dr	Pacifica	94044-3555	Primary education
Alto International School	475 Pope Street	Menlo Park	94025	Primary education
American Harp Society	646 Marlin Ct	Redwood City	94065-1269	Sports and recreation education
Amethyst Light	1620 Palmetto Ave Ste A	Pacifica	94044-2289	Retail sale of other second- hand goods in stores (not incl. antiques)
Animal Dental Clinic	987 Laurel St	San Carlos	94070-3916	Veterinary activities
Ansel Adams Gallery	850 Oneill St	Belmont	94002-3838	Retail sale of other second- hand goods in stores (not incl. antiques)
Anx Home Healthcare	455 Hickey Boulevard, Suite 415	Daly City	94015	Hospital activities
Aragon High School	900 Alameda De Las Pulgas	San Mateo	94402-3399	Primary education
Art in Stone Monuments	1174 El Camino Real	Colma	94014-3212	Retail sale of other second- hand goods in stores (not incl. antiques)
Ascend Clinical, LLC	1400 Industrial Way	Redwood City	94063	Hospital activities
Atherton Wine Imports	83 Fleur Pl	Atherton	94027	Retail sale via stalls and markets of food, beverages and tobacco products

Baden High School	825 Southwood Dr	South San Francisco	94080-3106	Primary education
Bair Island Aquatic Center	1450 Maple St	Redwood City	94063-2719	Hunting, trapping and related service activities
Baking Arts	18 E 3rd Avenue	San Mateo	94401	Hunting, trapping and related service activities
Balsam Brands Group LLC	50 Woodside Plaza Suite 111	Redwood City	94061	Retail sale via stalls and markets of food, beverages and tobacco products
Barbara Butler Artist Builder, Inc.	325 So Maple Avenue #37	South San Francisco	94080	Retail sale of electrical household appliances in specialised stores
Bark Park Inc	840 Sweeney Ave	Redwood City	94063-3024	Farm animal boarding and care
Bautista Chiropractic Care	931 San Bruno Ave W Ste 7	San Bruno	94066-3435	Specialists medical practice activities
Bay Area Friendship Circle	3900 Fabian Way	Palo Alto	94303-4605	Other residential care activities n.e.c.
Bay Area House Call Physicians	4067 Transport St	Palo Alto	94303-4914	Medical nursing home activities
Bay Area Senior Services Inc.	1 Baldwin Ave	San Mateo	94401-3864	Other residential care activities n.e.c.
Bay Area Surgical Group	1849 Bayshore Hwy	Burlingame	94010-1215	Hospital activities
Bay Reprographic & Supply, Inc.	2692 Middlefield Rd Ste D	Redwood City	94063	Retail sale of other second-hand goods in stores (not incl. antiques)
Bay Sleep Clinic	830 Menlo Ave Ste 109	Menlo Park	94025-4734	Specialists medical practice activities
Bayshore Ambulance, Inc.	370 Hatch Dr	Foster City	94404	Other human health activities
Bayshore Animal Hospital	630 Donohoe St	East Palo Alto	94303-1909	Veterinary activities
Bayview Villa Assisted Living	777 Bayview Dr	San Carlos	94070-1667	Other residential care activities n.e.c.
Belmont Advanced Chiropractic	1601 El Camino Real Ste 301	Belmont	94002-3943	Specialists medical practice activities
Belmont Oaks Academy	2200 Carlmont Dr	Belmont	94002	Child day-care activities
Belmont Plaza Dental Care	390 El Camino Real Ste D	Belmont	94002-2006	Dental practice activities
Beresford Montessori	1717 Gum St	San Mateo	94402-3027	Child day-care activities

Bianchini's Market, Inc.	3130 Alpine Rd Ste 415	Portola Valley	94028	Other retail sale of food in specialised stores
Birches Residential Care	810 Sutter Ave	Palo Alto	94303-3941	Other residential care activities n.e.c.
Body Balance & Beyond	146 S Blvd	San Mateo	94402-2462	Hospital activities
Bowman Medical Supply	1200 Industrial Rd Ste 16	San Carlos	94070-4129	Retail sale of other second-hand goods in stores (not incl. antiques)
Boys & Girls Club North San Mateo County	201 W Orange Ave	South San Francisco	94080	Other residential care activities n.e.c.
Breathe California Golden Gate Public Health Partnership	2171 Junipero Serra Blvd Ste 720	Daly City	94014	Specialists medical practice activities
Briarwood Equine Clinic Inc.	4370 Alpine Rd	Portola Valley	94028-7952	Veterinary activities
Bridge School	1400 Hillside Blvd	South San Francisco	94080-1538	Primary education
Bright Star	498 Cunningham Way	San Bruno	94066-4100	Child day-care activities
Brisbane Recreation Dept	50 Park Pl	Brisbane	94005-1310	General public administration activities
Broadway Pharmacy	1300 Broadway	Burlingame	94010-3426	Other retail sale in non-specialised stores
Brookside Skilled Nursing Hospital	2620 Flores Street	San Mateo	94403	Other residential care activities n.e.c.
Burgess Memorial Pool	501 Laurel St	Menlo Park	94025-3449	Hunting, trapping and related service activities
Burgess Pediatrics	401 Burgess Dr Ste C	Menlo Park	94025-3476	Specialists medical practice activities
Burlingame Family Health	1820 Ogden Dr Ste 100	Burlingame	94010-5333	Hospital activities
Burlingame High School	1 Mangini Way	Burlingame	94010-1904	Primary education
Burlingame Family Pet Hospital	1808 Magnolia Ave	Burlingame	94010-4502	Veterinary activities
California College of Early Childhood Education	2333 S El Camino Real	San Mateo	94403-2271	Primary education
California Ear Institute	1900 University Ave Ste 101	Palo Alto	94303-2213	Hospital activities
California Hand & Wrist	104 St Matthews Ave	San Mateo	94401-2807	Hospital activities

California Sports & Family	1650 Industrial Rd	San Carlos	94070-4113	Specialists medical practice activities
Camino Real Pet Clinic	1317 Bayswater Ave	Burlingame	94010-4312	Veterinary activities
Canary Foundation	805 Veterans Blvd #301	Redwood City	94063	Social work activities without accommodation for the elderly and disabled
Canty Chiropractic	32 W 25th Ave Ste 100	San Mateo	94403-2265	Specialists medical practice activities
Cardiac Therapy Foundation of The Mid Peninsula	4000 Middlefield Rd Ste G8	Palo Alto	94303-4761	Other residential care activities n.e.c.
Care Plus	34 Capay Circle	South San Francisco	94080-4118	Other residential care activities n.e.c.
Carillon Pre-school at Christ Church	815 Portola Rd	Portola Valley	94028-7206	Child day-care activities
Carlmont Gardens Nursing Center	2140 Carlmont Drive	Belmont	94002	Other residential care activities n.e.c.
Carlmont High School	1400 Alameda De Las Pulgas	Belmont	94002-3585	Primary education
CBR Systems, Inc.	1200 Bayhill Dr 3rd Floor	San Bruno	94066	Other human health activities
Ccd School of Religion	300 Alameda De Las Pulgas	San Mateo	94402-3202	Primary education
Center for Independence of The Disabled	2001 Winward Way Ste 103	San Mateo	94404	Other residential care activities n.e.c.
Center For Learning And Autism Support Services Inc. (Class)	424 Peninsula Avenue	San Mateo	94401	Specialists medical practice activities
Chai Preschool	499 Boothbay Ave	Foster City	94404-3558	Child day-care activities
Charles Armstrong School	1405 Solana Dr.	Belmont	94002	Primary education
Cherok Chiropractic	328 N San Mateo Dr Ste C	San Mateo	94401-2514	Specialists medical practice activities
Child Care Coordinating Council of San Mateo County, Inc.	330 Twin Dolphin Dr Ste 119	Redwood City	94065	Other residential care activities n.e.c.
Cielo House Comprehensive Eating Disorder Treatment	750 El Camino Real	Burlingame	94010	Specialists medical practice activities

City Arms	90 Eureka Sq	Pacifica	94044-2653	Other retail sale of food in specialised stores
Ck-12 Foundation	3430 West Bayshore Road	Palo Alto	94303	Primary education
Coastside Children's Programs	494 Miramontes Ave	Half Moon Bay	94019	Other residential care activities n.e.c.
Coastside Veterinary Clinic	614 Purissima St	Half Moon Bay	94019-1933	Veterinary activities
Cohen Dental Care	931 S El Camino Real	San Mateo	94402	Dental practice activities
Coleman Children and Youth Services	459 Vienna St	San Francisco	94112-2831	Other residential care activities n.e.c.
Committee for Recognition of Nursing Achievement	499 Seaport Ct Ste 202	Redwood City	94063	Other residential care activities n.e.c.
Community Overcoming Relationship Abuse	2211 Palm Ave	San Mateo	94403-1814	Social work activities without accommodation for the elderly and disabled
Compass High School	2040 Pioneer Ct	San Mateo	94403	Primary education
Control Plastics	377 Oyster Point Blvd Ste 10	South San Francisco	94080	Retail sale of other second-hand goods in stores (not incl. antiques)
Cora-community Overcoming	1633 Bayshore Hwy Ste 280	Burlingame	94010-1515	Other residential care activities n.e.c.
Core Diagnostics Inc.	2458 Embarcadero Way	Palo Alto	94303	Other human health activities
Corinthians	800 Roble Ave	Menlo Park	94025-4908	Other residential care activities n.e.c.
Corte Madera Middle School	4575 Alpine Rd	Portola Valley	94028-8040	Primary education
Costano Elementary School	2695 Fordham St	East Palo Alto	94303-1207	Primary education
Cow Palace	2600 Geneva Ave	Daly City	94014-1554	Hunting, trapping and related service activities
Crystal Springs Pet Hospital	122 De Anza Blvd	San Mateo	94402	Veterinary activities
Crystal Springs Uplands School	400 Uplands Dr	Hillsborough	94010	Primary education
Curiodyssey	1651 Coyote Point Dr	San Mateo	94401	Social work activities without accommodation for the elderly and disabled

Daly City Public Library	40 Wembley Dr Wembly	Daly City	94015	Library activities
Danli Chiropractic & Wellness	340 Lorton Ave Ste 203	Burlingame	94010-4126	Specialists medical practice activities
David Starr Jordan Middle School	750 N California Ave	Palo Alto	94303-3629	Primary education
Daybreak Shelter	639 Douglas Ave	Redwood City	94063-3437	Other residential care activities n.e.c.
Destira, Inc.	116 El Camino Real	San Carlos	94070	Retail sale of electrical household appliances in specialised stores
Diabetes Technology Society	845 Malcolm Rd Ste 5	Burlingame	94010-1402	Other residential care activities n.e.c.
Digestive Care Medical Center	1000 Laurel St Ste A	San Carlos	94070-3955	Specialists medical practice activities
Dog's Life a	885 Commercial St	Palo Alto	94303-4906	Farm animal boarding and care
Family Connections	2565 San Bruno Ave	San Francisco	94134-1538	Other residential care activities n.e.c.
Family Housing & Adult Resources	20 E 20th Ave	San Mateo	94403-1319	Other residential care activities n.e.c.
First Chance	383 E Grand Ave Ste D	South San Francisco	94080-6234	Social work activities without accommodation for the elderly and disabled
Fisch, Joan	1300 University Dr Ste 6	Menlo Park	94025-4254	Other residential care activities n.e.c.
Half Moon Bay Parks & Rec Department	535 Kelly St	Half Moon Bay	94019-1719	General public administration activities
Happy Hall Preschool	233 Santa Inez Ave	San Bruno	94066-5212	Child day-care activities
Hawthorn Health Partners	800 Airport Blvd Ste 410	Burlingame	94010-1929	Hospital activities
Hc Language Solutions, Inc.	950 Tower Ln Ste 390	Foster City	94404-2123	Social work activities without accommodation for the elderly and disabled
Health Strategies Group	303 Twin Dolphin Dr Ste 600	Redwood City	94065-1422	Other residential care activities n.e.c.
Heartbeat Project	1800 Broadway St Ste 3	Redwood City	94063-2044	Other residential care activities n.e.c.
Home & Hope	1720 El Camino Real Ste 7	Burlingame	94010-3226	Other residential care activities n.e.c.

InnVision Shelter Network	181 Constitution Dr	Menlo Park	94025	Social work activities without accommodation for the elderly and disabled
Jobtrain, Inc.	1200 Obrien Dr	Menlo Park	94025	Performing arts
Late Bloomers	50 Ben Franklin Ct	San Mateo	94401-4041	Retail sale of other second-hand goods in stores (not incl. antiques)
Lick-Wilmerding High School	755 Ocean Ave	San Francisco	94112	Primary education
Lite for Life	1199 Howard Ave Ste 102	Burlingame	94010-4227	Specialists medical practice activities
Lite for Life	1199 Howard Ave Ste 102	Burlingame	94010-4227	Specialists medical practice activities
Lite for Life	1199 Howard Ave Ste 102	Burlingame	94010-4227	Specialists medical practice activities
Little Wonders a Parent Child Center	225 Tilton Ave	San Mateo	94401-2825	Child day-care activities
Livewell Medical Clinic	1150 El Camino Real Ste 225	San Bruno	94066-2424	Hospital activities
Lomita Park Elementary School	200 Santa Helena Ave	San Bruno	94066-5331	Primary education
Los Cerritos Elementary School	210 W Orange Ave	South San Francisco	94080-4444	Primary education
Lovely Martha Sportfishing	218 Hazelwood Dr	South San Francisco	94080-5805	Hunting, trapping and related service activities
Lucky Chances Casino	1700 Hillside Blvd	Colma	94014-2801	Gambling and betting activities
Lydian Academy Llc	815 El Camino Real	Menlo Park	94025-4807	Primary education
Macs Childrens & Family	41 Garibaldi St	Daly City	94014-2248	Child day-care activities
Magnolia of Millbrae, Inc.	201 Chadbourne Ave	Millbrae	94030	Other residential care activities n.e.c.
Magnolia Senior Ctr	601 Grand Ave	South San Francisco	94080-3552	Social work activities without accommodation for the elderly and disabled
Mancave Memorabilia Llc	957 Industrial Rd Ste C	San Carlos	94070-4152	Retail sale of other second-hand goods in stores (not incl. antiques)
Many Lives Chinese Medicine	499 Seaport Ct Ste 101	Redwood City	94063-2782	Hospital activities
Manyak Tanya	100 S Ellsworth Ave Ste 208	San Mateo	94401-3932	Dental practice activities

Maryland Home	2028 Maryland St	Redwood City	94061-3230	Medical nursing home activities
Matched Caregivers	2825 El Camino Real	Redwood City	94061-4001	Hospital activities
Mateo Lodge, Inc.	420 Cassia St	Redwood City	94063	Specialists medical practice activities
Maxwell's Senior Care Services	846 Andromeda Ln	Foster City	94404-2803	Other residential care activities n.e.c.
MD Collab Inc.	93 Lakewood Circle	San Mateo	94402	Hospital activities
Medical Care Professionals Inc.	363 S El Camino Real Ste 215	San Mateo	94402	Hospital activities
Medical Couriers Inc.	1282 Montgomery Ave	San Bruno	94066-1522	Other human health activities
Megabass Of America, Inc.	633 Quarry Rd Unit B	San Carlos	94070	Retail sale of electrical household appliances in specialised stores
Menlo Circus Club	190 Park Ln	Atherton	94027-4194	Social work activities without accommodation for the elderly and disabled
Menlo College	1000 El Camino Real	Atherton	94027-4300	First-degree level higher education
Menlo Medical Clinic	1300 Crane St	Menlo Park	94025-4283	Hospital activities
Menlo Park Dental Excellence	724 Oak Grove Ave Ste 120	Menlo Park	94025-4362	Dental practice activities
Menlo Park Public Library	800 Alma St	Menlo Park	94025	Library activities
Menlo School	50 Valparaiso Ave	Atherton	94025	Primary education
Mental Health Association of San Mateo County	2686 Spring St	Redwood City	94063	Social work activities without accommodation for the elderly and disabled
Mercy High School	2750 ADELIN DR	Burlingame	94010	Primary education
Merry Clinic LLC	370 San Bruno Ave West Ste F	San Bruno	94066	Hospital activities
Michaelian Endodontics	341 Gellert Blvd	Daly City	94015-2616	Dental practice activities
Mid -peninsula High School	1340 Willow Rd	Menlo Park	94025-1516	Primary education
Millbrae Montessori	797 Santa Margarita Ave Ste B	Millbrae	94030-1148	Child day-care activities

Millbrae Montessori	797 Santa Margarita Ave Ste B	Millbrae	94030-1148	Child day-care activities
Mills High School	400 Murchison Dr	Millbrae	94010	Primary education
Mills Montessori School	1400 Hillside Blvd	South San Francisco	94080-1538	Social work activities without accommodation for the elderly and disabled
Mills Peninsula Medical Group	57 El Camino Real	San Carlos	94070-2401	Hospital activities
Mission Hospice Of San Mateo County	1670 South Amphlett Blvd., Suite 300	San Mateo	94402	Other residential care activities n.e.c.
Modern Pacific	219 Lawrence Avenue	South San Francisco	94080	Retail sale via stalls and markets of food, beverages and tobacco products
Montessori School of Linda Mar Elementary, Inc	1220 Linda Mar Blvd	Pacifica	94044-4264	Primary education
Montessori-all Are Friends Preschool	1130 Balclutha Dr	Foster City	94404-1710	Child day-care activities
Msb	841 California Dr	Burlingame	94010-3604	Hospital activities
MYPLEASURE INC	1061 Sneath Ln	San Bruno	94066-2311	Retail sale via stalls and markets of food, beverages and tobacco products
Nakamitsu & Macapagal Dental	1131 Mission Rd	South San Francisco	94080-1302	Dental practice activities
National Center for Equine Facilitated Therapy	880 Runnymede Rd	Woodside	94062	Other residential care activities n.e.c.
Nesbit Elementary School	500 Biddulph Way	Belmont	94002-2796	Primary education
Neurolink Chiropractic	177 Bovet Rd	San Mateo	94402-3116	Specialists medical practice activities
New Perspectives	1798 Bay Rd # B	East Palo Alto	94303-1611	Other residential care activities n.e.c.
Newbold Chiropractic	455 Ave Alhambra	El Granada	94018	Specialists medical practice activities
Nick Foster Entertainment	1324 Rollins Rd	Burlingame	94010-2410	Hunting, trapping and related service activities
Noble Beast	267 Baldwin Ave	San Mateo	94401-3914	Farm animal boarding and care
North Peninsula Veterinary	227 N Amphlett Blvd	San Mateo	94401-1805	Veterinary activities

Nueva School	6565 Skyline Boulevard	Hillsborough	94010	Primary education
Nursing and Rehab at Home	1660 S Amphlett Boulevard, Suite 112	San Mateo	94402	Hospital activities
O'brien Animal Transportation	1169 Chess Dr Ste J	Foster City	94404-1120	Veterinary activities
Omniox	1010 Haddon Dr	San Mateo	94402-2504	Hospital activities
Optometrist Dr Aw. Meyer	94 Serramonte Center	Daly City	94015-2345	Specialists medical practice activities
Orchid Villa	1239 Middle Ave	Menlo Park	94025-5845	Medical nursing home activities
Ormondale Elementary School	4575 Alpine Rd	Portola Valley	94028-8040	Primary education
Orthoworks Orthodontics	883 Sneath Ln	San Bruno	94066-2409	Dental practice activities
Our Common Ground, Inc.	631 Woodside Rd	Redwood City	94061	Specialists medical practice activities
Our Lady of Angel Pre School	1341 Cortez Ave	Burlingame	94010-4714	Child day-care activities
Oxford Day Academy, Inc.	1001 BEECH ST	East Palo Alto	94303	Primary education
P G s p Inc	405 Broadway St	Redwood City	94063-3133	Hospital activities
Pacific Autism Learning Services	1710 S Amphlett Blvd Ste 314	San Mateo	94402-2736	Other residential care activities n.e.c.
Pacific Dental Center	100 S El Camino Real	San Mateo	94401-3810	Dental practice activities
Pacific Eye Specialists	1850 Sullivan Ave Ste 540	Daly City	94015-2215	Hospital activities
Pacific Gateway Concessions, LLC	207 Lawrence Ave	South San Francisco	94080	Retail sale of electrical household appliances in specialised stores
Pacific Genuity, Inc.	1091 Industrial Rd Suite 105	San Carlos	94070	Retail sale via stalls and markets of food, beverages and tobacco products
Pacific Rim International School	630 Hickey Blvd	Pacifica	94044-1544	Primary education
Pacific Service Center	543 Vista Mar Ave	Pacifica	94044-1951	Other residential care activities n.e.c.
Pacifica Linda Mar, Inc.	751 San Pedro Terrace Rd	Pacifica	94044	Hospital activities
Pacifica Pet Hospital	4300 Coast Hwy	Pacifica	94044-3025	Veterinary activities

Padma	2309 S El Camino Real	San Mateo	94403-2213	Retail sale of other second-hand goods in stores (not incl. antiques)
Palcare	945 California Dr	Burlingame	94010-3605	Social work activities without accommodation for the elderly and disabled
Palo Verde Elementary School	3450 Louis Rd	Palo Alto	94303-4403	Primary education
Parents Nursery School	2328 Louis Rd	Palo Alto	94303-3635	Child day-care activities
Park Ave Care Homes	1628 Celeste Dr	San Mateo	94402-2602	Other residential care activities n.e.c.
Park Towers	700 Laurel Ave	San Mateo	94401-4176	Other residential care activities n.e.c.
Patricia Volpe Otr	751 Alameda De Las Pulgas	Belmont	94002-1606	Hospital activities
Peabody Gallery	603 Santa Cruz Ave	Menlo Park	94025-4502	Retail sale of other second-hand goods in stores (not incl. antiques)
Peninsula Conflict Resolution Center	1660 S Amphlett Blvd Ste 219	San Mateo	94402	Other residential care activities n.e.c.
Peninsula Family Connections	415 Ivy Dr Bldg P9	Menlo Park	94025-1338	Primary education
Peninsula High School	300 Piedmont Ave	San Bruno	94066-3959	Primary education
Peninsula Holistic Health Center	53 N San Mateo Dr Ste B	San Mateo	94401-2887	Hospital activities
Peninsula Humane Society & SPCA	12 Airport Blvd	San Mateo	94401	Social work activities without accommodation for the elderly and disabled
Peninsula Interfaith Action	1336 Arroyo Ave	San Carlos	94070-3913	Other residential care activities n.e.c.
Peninsula Jewish Community Center	800 Foster City Blvd	Foster City	94404-2228	Social work activities without accommodation for the elderly and disabled
Peninsula Library System District	2471 Flores St	San Mateo	94403	Library activities
Peninsula Periodontal Associates	235 N San Mateo Dr Ste 100	San Mateo	94401-2672	Dental practice activities
Peninsula Pet Resort	851b Old County Rd	San Carlos	94070-4001	Veterinary activities
Peninsula Temple Sholom	1655 Sebastian Dr	Burlingame	94010-5899	Child day-care activities

Peninsula Urology Center, Inc.	3351 El Camino Real Ste 101	Atherton	94027-3802	Specialists medical practice activities
Peninsula Volunteers, Inc.	800 Middle Avenue	Menlo Park	94025	Social work activities without accommodation for the elderly and disabled
Periwinkle Custom Framing	Po Box 1792	Pacifica	94044-6792	Retail sale of other second-hand goods in stores (not incl. antiques)
Perpetual Help Home	103 N Grant St	San Mateo	94401-1910	Other residential care activities n.e.c.
Personalized Beauty Discovery, Inc.	201 Baldwin Ave	San Mateo	94401	Retail sale of cosmetic and toilet articles in specialised stores
Pescadero Elementary School Kindergarten	620 North St	Pescadero	94060	Primary education
Pet Express	100 N Hill Dr	Brisbane	94005-1017	Veterinary activities
Pets in Need	871 5th Ave	Redwood City	94063-3914	Social work activities without accommodation for the elderly and disabled
Phillip and Sala Burton High School	400 Mansell St	San Francisco	94134-1829	Primary education
Physician Focus, Inc.	1340 Bayshore Hwy	Burlingame	94010	Hospital activities
Physicians Integrated Medical Group, Inc.	273 Valley Dr	Brisbane	94005	Hospital activities
Pie Ranch	2080 Cabrillo Hwy	Pescadero	94060	Other residential care activities n.e.c.
Plumbing Apprenticeship Committee	1519 Rollins Rd	Burlingame	94010-2305	Performing arts
Pombra Dental Excellence	1252 El Camino Real Ste B	San Bruno	94066-1303	Dental practice activities
Ponderosa Elementary School	295 Ponderosa Rd	South San Francisco	94080-4299	Primary education
Ppi Knowledge Universe	3351 El Camino Real	Atherton	94027-3811	Other residential care activities n.e.c.
Premier Chiropractic Clinic	130 Shoreline Dr	Redwood City	94065	Specialists medical practice activities
Premier Dermatology	378 El Camino Real	San Carlos	94070-2408	Specialists medical practice activities
Prima Deli	2115 Roosevelt Ave	Redwood City	94061	Other retail sale of food in specialised stores

Professional Research Consulting, Inc.	1111 Bayhill Dr Suite 408	San Bruno	94066	Hospital activities
Project Ninety, Inc.	720 S B St	San Mateo	94401	Other residential care activities n.e.c.
Puente De La Costa Sur	Po Box 554	Pescadero	94060-0554	Other residential care activities n.e.c.
Pulmonary Associates	1720 El Camino Real Ste 150	Burlingame	94010-3231	Hospital activities
Ragadio Dental Group Inc.	1100 Geneva Ave	San Francisco	94112-3822	Dental practice activities
Ravenswood City Charter Schools	2086 Clarke Ave	East Palo Alto	94303-1916	Primary education
Ravenswood Family Health Ctr	100 Terminal Ave	Menlo Park	94025-1246	Hospital activities
Real Options for City Kids	590 Leland Ave	San Francisco	94134	Other residential care activities n.e.c.
Rebuilding Together Peninsula	Po Box 4031	Menlo Park	94026	Other residential care activities n.e.c.
Red Sea Market	1801 San Jose Ave	San Francisco	94112-2442	Other retail sale of food in specialised stores
Redwood City Public Library	1044 Middlefield Rd	Redwood City	94063	Library activities
Redwood Parents Nursery School	3997 Jefferson Ave	Emerald Hills	94062-3437	Child day-care activities
Redwood Pulmonary Medical Assoc	170 Alameda De Las Pulgas	Redwood City	94062-2751	Hospital activities
Reitman Physical Therapy	885 Oak Grove Ave Ste 101	Menlo Park	94025-4400	Specialists medical practice activities
Renew Laser Clinic	211 De Anza Blvd	San Mateo	94402-3989	Hospital activities
Rivera Chiropractic Group	1168 El Camino Real	San Carlos	94070-5001	Specialists medical practice activities
Rocketship Education	350 Twin Dolphin Drive, Suite 109	Redwood City	94065	Post-secondary non-tertiary education
Ronald C. Wornick School	800 Foster City Blvd	Foster City	94404-2228	Primary education
Russell Bede School	446 Turner Terrace	San Mateo	94401-2414	Primary education
Sacred Heart Schools, Atherton	150 Valparaiso Ave	Atherton	94025	Primary education
Sage Wellness Center Therapeutic	601 S B St	San Mateo	94401-4120	Hospital activities
Samaritan House	4031 Pacific Blvd	San Mateo	94403-4666	Other residential care activities n.e.c.

San Bruno Pet Hospital Inc.	1111 El Camino Real	San Bruno	94066-2405	Veterinary activities
San Bruno Skilled Nursing Hospital	890 El Camino Real	San Bruno	94066	Other residential care activities n.e.c.
San Carlos Library	610 Elementary Street	San Carlos	94070-8401	Library activities
South County Community Health Center Inc	2396 University Ave	East Palo Alto	94303-1617	Hospital activities
Staffing Home Care Inc	3540 Callan Blvd Ste 203	South San Francisco	94080-5100	Hospital activities
Thecarey School	1 Carey School Ln	San Mateo	94403-1268	Primary education
Tickets Express	747 Bermuda Dr	San Mateo	94403-1401	Hunting, trapping and related service activities
Tiny Treks	1121 Jefferson Ave	Redwood City	94063-1814	Primary education
Tollstrup Chiropractic	560 Masonic Way	Belmont	94002-2703	Specialists medical practice activities
Toni Ambus Dds	773 Jenevein Ave	San Bruno	94066-4231	Dental practice activities
Torah Academy	3070 Louis Rd	Palo Alto	94303-3952	Primary education
Treasure Market	933 Hamilton Ave	Menlo Park	94025-1431	Other retail sale of food in specialised stores
Trinity School	2650 Sand Hill Rd	Menlo Park	94025	Primary education
Truemed, Inc	400 Oyster Point Boulevard, Suite 201	South San Francisco	94080	Hospital activities
Typewritorium Company Inc.	200 Valley Drive Suite 12	Brisbane	94005	Retail sale of electrical household appliances in specialised stores
Tyson Kennels	3735 Haven Ave	Menlo Park	94025-1011	Farm animal boarding and care
Universal Investments Inc.	11 Saint Francis Sq	Daly City	94015-4014	Dental practice activities
University Art Center, Inc.	2550 El Camino Real	Redwood City	94061	Retail sale of electrical household appliances in specialised stores
Vascular Cures	555 Price Ave Ste 180	Redwood City	94063	Social work activities without accommodation for the elderly and disabled
Voices of Recovery San Mateo County	310 Harbor Blvd	Belmont	94002	Other residential care activities n.e.c.
Welbe Health LLC	405 El Camino Real Suite 248	Menlo Park	94025	Medical nursing home activities

West Coast Surgical Llc	141 California Ave Ste 101	Half Moon Bay	94019-4073	Hospital activities
West Coast Wellness	1840 Gateway Dr Ste 125	San Mateo	94404-4029	Hospital activities
West Orange Library	840 W Orange Ave	South San Francisco	94080-3125	Library activities
Westbay Nephrology Associates	1498 Southgate Ave	Daly City	94015-4015	Hospital activities
Westlake Elementary School	80 Fieldcrest Dr	Daly City	94015-1099	Primary education
Whipple Avenue Pet Hospital	635 Whipple Ave	Redwood City	94063-1125	Veterinary activities
White Oaks Elementary School	1901 White Oak Way	San Carlos	94070-4799	Primary education
Wildlife Associates	Po Box 3098	Half Moon Bay	94019-3098	Social work activities without accommodation for the elderly and disabled
Willow Clinic	795 Willow Rd	Menlo Park	94025-2539	Hospital activities
Wings Learning Center, Inc	2303 Trousdale Dr	Burlingame	94010-5704	Primary education
Woodland School	360 La Cuesta Dr	Portola Valley	94028-7535	Primary education
Woodside Preschool	3195 Woodside Rd	Woodside	94062-2598	Child day-care activities
Woodside Priory School		Portola Valley	94028	Primary education
Workspace Innovations, Inc.	240 El Camino Real	Belmont	94002-2018	Retail sale of other second-hand goods in stores (not incl. antiques)
Zouves Fertility Center	901 Campus Dr	Daly City	94015-4900	Specialists medical practice activities

Appendix C: Kiosk Signage, Mail-Back Inserts and Educational Brochure

Note: All Promotional material is meant to be a sample of Inmar’s capabilities and intent only, and all material will be coordinated with other Program Operators for a single system and submitted to the Division for final approval.

Kiosk prototype and signage

ACCEPTED
 MEDICATIONS IN ANY DOSAGE FORM, EXCEPT FOR THOSE LISTED BELOW, IN THEIR ORIGINAL CONTAINER OR SEALED BAG.

NOT ACCEPTED
 HERBAL REMEDIES, VITAMINS, SUPPLEMENTS, COSMETICS, OTHER PERSONAL CARE PRODUCTS, MEDICAL DEVICES, BATTERIES, MERCURY-CONTAINING THERMOMETERS, SHARPS, AND ILLICIT-DRUGS.

Name: 123 Pharmacy
 Contact: (555) 555-5555



CONSUMER DRUG TAKE-BACK (PROGRAMA DE ELIMINACIÓN DE MEDICAMENTOS)

1 Pull to open drawer
Jale para abrir el cajón

2 Place medications inside
Coloque los medicamentos adentro

3 Close the drawer
Cierre el cajón

ACCEPTED (ACEPTADOS)

Unused or expired prescription medication
 (Including Schedule II-V controlled substances)
Medicamentos con receta no consumidos o vencidos (incluidas las sustancias controladas de clasificación II a V)

Unused or expired over-the-counter medication
Medicamentos de venta libre, no consumidos o vencidos

Pet Medication
Medicamentos para mascotas

NOT ACCEPTED (NO ACEPTADOS)

Schedule I controlled substances
Sustancias controladas de clasificación I

Illegal drugs
Drogas ilegales

Thermometers
Termómetros

Needles
Agujas

Aerosol Cans
Latas de aerosoles

MEDICINE DISPOSAL

Eliminación de medicamentos

药物处置

Pagtatapon ng gamot



SAFELY DISPOSE OF UNWANTED & EXPIRED MEDICINES



01

Cross out or remove personal identifying information from the medicine bottle.



02

Leave the product in its original container or place solid medicines in a sealed plastic bag.*

*If transferring medications to a sealed bag, please be sure to recycle all remaining packaging.



03

Put medicine in the kiosk.

ONLY SCHEDULE II-V CONTROLLED AND NON-CONTROLLED SUBSTANCES THAT ARE LAWFULLY POSSESSED BY THE ULTIMATE USER ARE ACCEPTABLE TO BE PLACED IN THE KIOSK. SCHEDULE I CONTROLLED SUBSTANCES, ILLICIT OR DANGEROUS SUBSTANCES, AND ANY CONTROLLED SUBSTANCES NOT LAWFULLY POSSESSED BY THE ULTIMATE USER MAY NOT BE PLACED IN THE KIOSK.

For more information about the drug disposal program, please go to safemedicinedrop.com or call 1-888-371-0717.



Promotional Brochure for Residents

PROTECT YOUR FAMILIES, COMMUNITIES, AND THE ENVIRONMENT
SAFELY DISPOSE OF UNUSED MEDICINES

WHAT SHOULD YOU DO WITH YOUR EXPIRED OR UNWANTED MEDICINES

There are a number of ways to dispose of expired or unwanted medications.

Go to www.safemedicatedrop.com to learn more.

CONVENIENT KIOSK LOCATIONS

MAIL-BACK

TAKE-BACK EVENTS

For more information about the program, go to www.safemedicatedrop.com or call 1-888-371-0717

WHY IS SAFE DRUG DISPOSAL IMPORTANT FOR PUBLIC HEALTH?

Proper disposal of unused drugs saves lives and protects the environment.

- Unused or expired prescription medications can lead to accidental poisoning, overdose, and abuse.
- Unused prescription drugs thrown in the trash can be retrieved, sold, or used illegally.
- Unused medications flushed down the toilet can contaminate water.

PROTECT YOUR FAMILIES, COMMUNITIES, AND THE ENVIRONMENT
SAFELY DISPOSE OF UNUSED MEDICINES

BEFORE DISPOSAL CHECK THE PACKAGE

If there are specific instructions for disposal on the label, package or package insert, please follow those instructions.

DISPOSAL OPTIONS

- CONVENIENT KIOSK DROP OFF LOCATIONS**
 To find drug disposal kiosk drop-off sites in your area, visit www.safemedicatedrop.com.
- MAIL-BACK ENVELOPES**
 Mail-Back Services for Unwanted Medicines. Visit the Mail-Back section of www.safemedicatedrop.com to order a Mail-Back Package.
- TAKE-BACK EVENTS**
 Local Take-Back events offer residents a free and convenient way to dispose of expired or Unwanted Medicines. Visit the Take-Back Events section of the DEA site at takebackday.dea.gov for information on events in your area.

For more information about the program, go to www.safemedicatedrop.com or call 1-888-371-0717

WHAT CAN YOU DISPOSE OF IN A KIOSK OR MAILBACK ENVELOPE?

ACCEPTED:
 Medications in any dosage form, except for those listed below, in their original container or sealed.*

*If transferring medications to a sealed bag, please be sure to recycle all remaining packaging

NOT ACCEPTED:
 Herbal remedies, vitamins, supplements, cosmetics, other personal care products, medical devices, batteries, mercury-containing thermometers, sharps, and illicit drugs.

This material has been provided for the purpose of compliance with legislation and does not necessarily reflect the views of Inmar Intelligence or the Producers participating in the Inmar Intelligence (Source: U.S. Food and Drug Administration) Product Stewardship Plan

ICT1289 CDTB 5C, CC 07/16/2021

Mail-back Inserts



MAIL-BACK PACKAGE IS FOR UNWANTED OR EXPIRED MEDICATIONS



ACCEPTED

Medications in any dosage form, except those listed below, in their original container or sealed bag.*

*If transferring medications to a sealed bag, please be sure to recycle all remaining packaging.

NOT ACCEPTED

Herbal remedies, vitamins, supplements, cosmetics, other personal care products, inhalers, medical devices, batteries, mercury-containing thermometers, sharps, and illicit drugs.

To protect your privacy, consumers are reminded to remove all personally identifiable information on prescription labels or materials before using any of the disposal options listed above.

This material has been provided for the purpose of compliance with legislation and does not necessarily reflect the views of Inmar Intelligence or the Producers participating in the Inmar Intelligence Product Stewardship Plan.

MAIL-BACK PACKAGE IS FOR **INHALERS**



ACCEPTED

Inhalers

NOT ACCEPTED

Unwanted medicines that are not inhalers, herbal remedies, vitamins, supplements, cosmetics, other personal care products, medical devices, batteries, mercury-containing thermometers, sharps, and illicit drugs.

Note: Only place undamaged inhalers in their original containers in the Inhaler Mail-Back Package. Inhaler Mail-Back Packages can only be used for inhalers and cannot accept other types of items.

To protect your privacy, consumers are reminded to remove all personally identifiable information on prescription labels or materials before using any of the disposal options listed above.

This material has been provided for the purpose of compliance with legislation and does not necessarily reflect the views of Inmar Intelligence or the Producers participating in the Inmar Intelligence Product Stewardship Plan.

MAIL-BACK PACKAGE IS FOR
PRE-LOADED PRODUCTS
CONTAINING A SHARP
AND AUTO-INJECTORS



ACCEPTED

Pre-loaded products containing a sharp and auto-injectors.

NOT ACCEPTED

Unwanted medicines that are not pre-loaded products containing a sharp or auto-injectors, inhalers, herbal remedies, vitamins, supplements, cosmetics, other personal care products, medical devices, batteries, mercury-containing thermometers, sharps, and illicit drugs.

Note: Injector Mail-Back Packages can only be used for pre-filled injector products and cannot accept other types of items.

This material has been provided for the purpose of compliance with legislation and does not necessarily reflect the views of Inmar Intelligence or the Producers participating in the Inmar Intelligence Product Stewardship Plan.

Appendix D: Training Material

Training material provided to Authorized Collectors include:

1. FAQs
2. Container Instructions
3. Steps to Start Document
4. Installation Reference Guide
5. Serialization Tracker

All of the aforementioned documents are provided on the following pages.

Note: Training materials will be updated upon Plan approval to include images reflecting appropriate PPE recommended for operating a Kiosk and to include information specific to the County of San Mateo Safe Drug Disposal Program.

GETTING STARTED

KIOSK

You will receive your Consumer Drug Take-Back kiosk and your supplies in separate shipments. After unpacking the Consumer Drug Take-Back kiosk, it must be installed according to the “Responsible Disposal Act” Rule which means it must be connected to a wall or the floor ensuring the kiosk is secure. Your kiosk will come pre-drilled in the bottom to make installation easier. Please see the installation instructions included in this email.

Your usage of the Inmar Consumer Drug Take-Back Program indicates your agreement to accept responsibility for following the Federal and State Guidelines. DEA’s Final Rule, which implements the Secure and Responsible Drug Disposal Act of 2010 (“the Disposal Act”).

SUPPLIES

After completing the proper installation of your Consumer Drug Take-Back kiosk, you should unpack your supplies.

Included are supplies to operate your Consumer Drug Take-Back program for 3 shipments. Upon Inmar’s receipt of your second container (return) shipment, we will automatically send your next 3 shipment supply package so you will always have the necessary supplies on hand. Staged shipping of your supplies alleviates your need to store large supply quantities.

Each shipment contains 3 individually-packaged kits with unique components to each kit. DO NOT rearrange contents between kits.

Each kit contains one of each of the following:

- Serialized Inner Liner
- Absorption pad
- Serialization Tracking Sheet (emailed separately)
- Black Zip Tie
- Set of instructions (Single Page)
- Numbered and pre-labeled cardboard box

It is important for you to document receipt of the serialized Inner Liners on your tracking form. To assist, Inmar has provided the Serialization Tracking sheet (Inner Liner Tracking Form). Maintain a copy of the completed Serialization Tracking Sheet in your files for at least 3 years (at the collector’s registered location). Refer to 16 CCR §1776.6.

CONSTRUCTING YOUR INNER CONTAINER

Construct 1 cardboard container applying an appropriate amount of tape to the bottom to ensure safe transportation. Seal the middle seam and both outside seams. Leave no untaped spaces along the seams and no less than 3 inches of tape overhang on each side. We recommend 2 strips of tape across the bottom seam and 2 strips of tape over the edge seams and 2 strips of tape across the bottom of the container placed diagonally. See illustration to right.

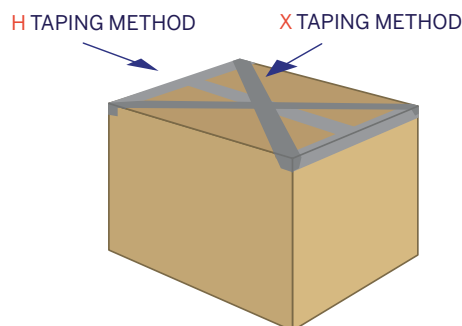

NOTE: All direct contact with the unsealed Consumer Drug Take-Back liner must be performed by two pharmacy personnel.

PREPARING YOUR CONTAINER FOR USAGE

1. Place Serialized Inner Liner into the box and fold excess material at top over box flaps. Leave Black Zip Tie taped to the Liner for later use. (When inserting Inner Liner, check to ensure Serial Number on Serialized Inner Liner matches Serial Number on the shipping container.)
2. Place absorbent pad into the installed Liner.
3. Install the lined box (now the "Container") into the Collection Kiosk.
4. Immediately document installation of Container (column 3 of the Serialization Tracking Sheet).
5. Store remaining spare kits securely for future use.
6. Lock bottom door and unlock top door to begin CDTB collection.

NOTE: All direct contact with the unsealed Consumer Drug Take-Back liner must be performed by two pharmacy personnel.

PREPARING YOUR CONTAINER FOR SHIPPING

Note: The total weight of the Container ready for shipping MAY NOT EXCEED 66 POUNDS IN WEIGHT.

1. Unlock and open bottom door.
2. Remove full Container from Collection Kiosk.
DO NOT sort, count or inventory pharmaceuticals or touch contents of Liner prior to sealing.
3. Immediately seal the Serialized Inner Liner by gathering the top of the Liner, bending the gathered portion at the halfway point and folding the top half alongside the bottom half. For extra security, bend the gathered portion at the halfway point a 2nd time. While folding Liner, keep Serial Number on Liner visible. Securely cinch the provided Black Zip Tie around both halves of the gathered portion of the Liner to secure the top. Ensure that the zip tie is completely above the exposed end of the top half of the gathered portion and that the zip tie is fully tightened. This will provide an airtight seal at the open end of the Liner to prevent leakage of any trace liquids that may be inside. See next page for illustration.
4. Close and tape the box top. Seal the middle seam and both outside seams. Leave no untaped spaces along the seams and no less than 3 inches of tape overhang on each side. We recommend 2 strips of tape across the top seam and 2 strips of tape over the edge seams and 2 strips of tape across the top of the container placed diagonally. See illustration of taping method above.
5. Document removal of Container (in column 4 of Serialization Tracking Sheet).
6. Store the sealed Container in a secure location until shipped.

SHIPPING AND RECORD KEEPING

Note: Container is pre-labeled and ready to return. The marking requirements of 49 CFR 172.301(c) do not apply. The container shall not contain any markings to indicate that the contents contain controlled substances.

1. Ship in accordance with the DOT Special Permit.
Container comes pre-paid and pre-labeled for shipping.
2. When the Liner is shipped, complete column 5 on the Serialization Tracking Sheet. The completed Serialization Tracking Sheet is a record of Liner Events and should be filed in accordance with DEA guidelines. Schedule a pickup on FedEx.com by clicking "Shipping" then from the drop-down menu selecting "Schedule & Manage Pickups."
3. Maintain a copy of the completed Serialization Tracking Sheet in your files for at least 3 years (at the collector's registered location). Refer to 16 CCR §1776.6.
4. Inmar will maintain your modified Form 41 noting destruction date and time on file and will provide it to you upon request.

QUICK STEPS

TO START

- 01** Install the Consumer Drug Take-Back Kiosk per DEA guidelines.
- 02** Properly tape container at bottom.
- 03** Place Serialized Inner Liner inside with top folded over container flaps.
(When inserting Serialized Inner Liner, check to ensure Serial Number on Inner Liner matches Serial Number on the shipping container.)
- 04** Place absorbent pad in bottom of Serialized Inner Liner.
- 05** Document the installation of the container on the Serialization Tracking Sheet.
- 06** Install container inside Consumer Drug Take-Back kiosk.
- 07** Lock bottom door and unlock top door to begin drug take-back collection.

TO CLOSE

- 01** Open bottom door.
- 02** Remove full container, total weight of container **may not exceed 66lbs in weight.**
- 03** Ensure the Serial Number is visible before using a zip tie to secure Serialized Inner Liner bag top.
- 04** Document the removal of the container on the Serialization Tracking Sheet.
- 05** Properly tape container at top.
- 06** Container is pre-labeled for return shipment.
- 07** Schedule pickup with FedEx.

NOTE: All direct contact with the unsealed Consumer Drug Take-Back liner must be performed by two pharmacy personnel.

HOW TO SEAL THE LINER TO PREPARE FOR SHIPPING

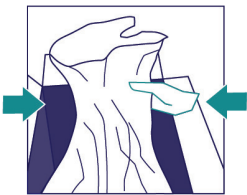

- 01**
Immediately seal the Serialized Opaque Liner by gathering the top of the Liner.

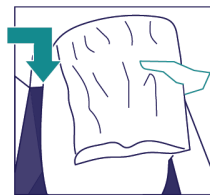

- 02**
Bend the gathered portion at the halfway point and fold the top half alongside the bottom half.

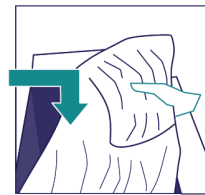

- 03**
Repeat Step 2 - Again bend the gathered portion at the halfway point and folding the top half alongside the bottom half.

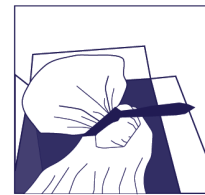

- 04**
Cinch and fully tighten the provided Black Zip Tie around both halves of the gathered portion of the Liner to secure the top.

1. MAINTENANCE AND CLEANLINESS OF KIOSK

The kiosk should be kept free of dirt and debris both inside and out. After an inner liner is removed for shipping, the pharmacist or servicing technician should look around the inside of the kiosk as well as the outside. The interior and exterior of the kiosk should be kept clean and free of

debris so as to not disrupt the intended functioning of the kiosk. Make sure the drop-door is in proper working order at all times when unlocked. In the event of any malfunction or maintenance needs, refer to procedures for requesting maintenance below.

2. PROCEDURES FOR REQUESTING MAINTENANCE

Should any portion of the kiosk become inoperable (key is lost, lock malfunctions, door hinge becomes unusable, etc.), Inmar's helpdesk can be reached by emailing take-back@inmar.com and describing the issue at hand. This inbox is

monitored by a team of people who are fully dedicated to the consumer drug take-back team at Inmar. The team will triage the request, contact the pharmacist or pharmacy manager if needed and solve the issue at hand.

3. PROCEDURES FOR ENSURING THAT THE CONTAINER IS REMOVED IN A TIMELY MANNER AND WHAT TO DO IF IT'S NOT.

The pharmacist should remove the container when it is full and prepare for shipping as described on this training document. After filling out the necessary information on the FedEx ship manager site, or providing the information via telephone, the liner should be securely locked in a location in

the pharmacy until it is picked up by FedEx personnel. If for any reason the pickup does not happen within 48 hours after being scheduled, please reach out to take-back@inmar.com and a consumer drug take-back team member will assist with this process.





LIFE **IN** CHECK™
CONSUMER DRUG TAKE-BACK

COLLECTION CONTAINER VISUAL INSTRUCTIONS

CONSTRUCTION, INSTALLATION, REMOVAL
AND SHIPPING OF COLLECTION CONTAINER

CALIFORNIA GUIDELINES

Questions: Contact Consumer Drug Take-Back Client Service Team
take-back@inmar.com

1-800-350-0396 Option 6, Mon-Fri 8am-5pm EST

KIT CONTENTS

Each shipment contains 3 individually packaged kits with unique components to each kit.

DO NOT rearrange contents between kits.

THE KIT:

- 1 The kit will arrive in a package similar to this.
- 2 The kit will include three numbered and pre-labeled boxes.



Each kit contains one of each of the following items:

- 1 Zip tie
- 2 Absorption pad
- 3 Inner liner
- 4 Numbered and pre-labeled box



IMPORTANT:

For every shipment – serial number on inner liner & serial number on cardboard container **MUST MATCH**.

NOTE: All direct contact with the LifeInCheck Consumer Drug Take-Back Container should be performed by two pharmacy personnel.

KIT INSTRUCTIONS— INSTALLING A NEW COLLECTION CONTAINER

1 Document the serial number and receipt of each inner liner on the Drug Disposal Serialization Tracking Sheet.

DRUG DISPOSAL SERIALIZATION TRACKING SHEET INNER LINER TRACKING FORM					
Name of Collecting Pharmacy		Address of Collecting Pharmacy		Collecting Pharmacy DEA #	
Size of Liner		Address of Reverse Distributor/Disposal Site		Reverse Distributor/Disposal Site DEA #	
SERIAL NUMBER	Date Liner Acquired (Purchase & Signature)	Date Liner Installed (Purchase & Signature)	Date Removed (Purchase & Signature)	Date Transferred to Storage (Purchase & Signature)	Date Shipped (Purchase & Signature)
Ex: 32567	4/26/19 John Jones Sally Smith	4/26/19 John Jones Sally Smith Sally Smith	5/26/19 John Jones Sally Smith Sally Smith	5/26/19 John Jones Sally Smith Sally Smith	5/23/19 John Jones Sally Smith Sally Smith

2 Close and tape the box bottom. Seal the middle seam and both outside seams. Leave no un-taped spaces along the seams. We recommend 1 strip of tape across the bottom seam, 2 strips of tape over the edge seams and 2 strips of tape across the bottom of the box placed diagonally. See illustration to right.

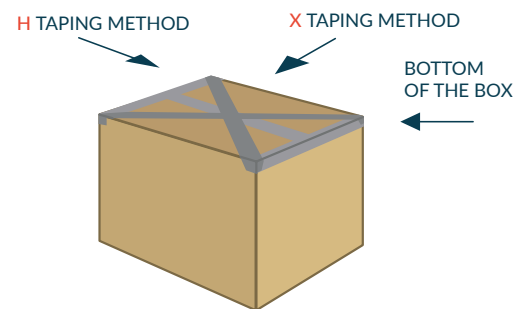

3 Place inner liner into the box and fold excess material at top over box flaps.



KIT INSTRUCTIONS— INSTALLING A NEW COLLECTION CONTAINER

4 Tape the zip tie to the inside of the door for later use.



5 Place absorbent pad into the installed inner liner.



6 Install the lined box (now the “Container”) into the collection kiosk.



KIT INSTRUCTIONS— INSTALLING A NEW COLLECTION CONTAINER

7 Immediately document installation of Container on the Drug Disposal Serialization Tracking Sheet.

Name of Collecting Pharmacy		Address of Collecting Pharmacy		Collecting Pharmacy DEA #	
Size of Liner		Address of Reverse Distributor/Disposal Site		Reverse Distributor/Disposal Site DEA #	
SERIAL NUMBER	Date Liner Acquired (Pharmacy)	Date Liner Installed (Pharmacy & Signatures)	Date Removed (Pharmacy & Signatures)	Date Transferred to Storage (Pharmacy & Signatures)	Date Shipped (Pharmacy & Signatures)
Ex: 32587	4/26/19 <i>John, Yvonne</i>	4/26/19 John Jones <i>John, Yvonne</i> Sally Smith <i>Sally Smith</i>	5/26/19 John Jones <i>John, Yvonne</i> Sally Smith <i>Sally Smith</i>	5/26/19 John Jones <i>John, Yvonne</i> Sally Smith <i>Sally Smith</i>	5/27/19 John Jones <i>John, Yvonne</i> Sally Smith <i>Sally Smith</i>

8 Lock the bottom door and unlock the drop door at the top of the kiosk to begin drug disposal collection.



9 Store remaining spare kits securely for future use.



10 Use the Drug Disposal Serialization Tracking Sheet to document all “inner liner events.”

Name of Collecting Pharmacy		Address of Collecting Pharmacy		Collecting Pharmacy DEA #	
Size of Liner		Address of Reverse Distributor/Disposal Site		Reverse Distributor/Disposal Site DEA #	
SERIAL NUMBER	Date Liner Acquired (Pharmacy)	Date Liner Installed (Pharmacy & Signatures)	Date Removed (Pharmacy & Signatures)	Date Transferred to Storage (Pharmacy & Signatures)	Date Shipped (Pharmacy & Signatures)
Ex: 32587	4/26/19 <i>John, Yvonne</i>	4/26/19 John Jones <i>John, Yvonne</i> Sally Smith <i>Sally Smith</i>	5/26/19 John Jones <i>John, Yvonne</i> Sally Smith <i>Sally Smith</i>	5/26/19 John Jones <i>John, Yvonne</i> Sally Smith <i>Sally Smith</i>	5/27/19 John Jones <i>John, Yvonne</i> Sally Smith <i>Sally Smith</i>

NOTE: All direct contact with the LifeInCheck Consumer Drug Take-Back Container should be performed by two pharmacy personnel.

KIT INSTRUCTIONS— REMOVING AND SEALING A FULL COLLECTION CONTAINER

Note: The total weight of the Container ready for shipping may not exceed 66 pounds.

- 1 Unlock and open bottom door.



- 2 Remove full Container from collection kiosk. **DO NOT** sort, count or inventory pharmaceuticals or touch contents of inner liner prior to sealing.



KIT INSTRUCTIONS— REMOVING AND SEALING A FULL COLLECTION CONTAINER

- 3** Immediately seal the inner liner by gathering the top of the liner.
- 4** Bend the gathered portion at the halfway point and fold the top half alongside the bottom half.
- 5** Repeat Step 4 - Again bend the gathered portion at the halfway point and fold the top half alongside the bottom half.



KIT INSTRUCTIONS— REMOVING AND SEALING A FULL COLLECTION CONTAINER

- 6** Cinch and fully tighten the provided zip tie around both halves of the gathered portion of the liner to secure the top.



- 7** Close and tape the box top. Seal the middle seam and both outside seams. Leave no un-taped spaces along the seams. We recommend 1 strip of tape across the top seam, 2 strips of tape over the edge seams and 2 strips of tape across the top of the Container placed diagonally. See illustration to right.

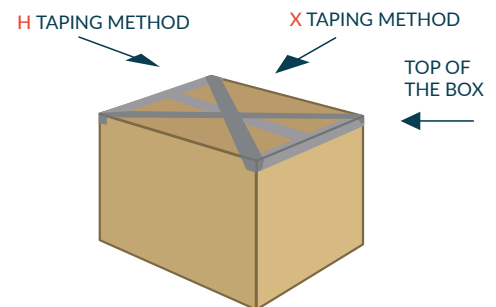

KIT INSTRUCTIONS— REMOVING AND SEALING A FULL COLLECTION CONTAINER

8 Document removal of Container on the Drug Disposal Serialization Tracking Sheet.

DRUG DISPOSAL SERIALIZATION TRACKING SHEET INNER LINER TRACKING FORM					
Name of Collecting Pharmacy		Address of Collecting Pharmacy		Collecting Pharmacy DEA #	
Size of Liner		Address of Reverse Distributor/Disposal Site		Reverse Distributor/Disposal Site DEA #	
1 SERIAL NUMBER	2 Date Liner Acquired (Signature)	3 Date Liner Installed (Name & Signature)	4 Date Removed (Name & Signature)	5 Date Transferred to Storage (Name & Signature)	6 Date Shipped (Name & Signature)
Ex: 32587	4/26/19 <i>Johanna</i>	4/26/19 John Jones Sally Smith <i>Sally Smith</i>	5/26/19 John Jones Sally Smith <i>Sally Smith</i>	5/26/19 John Jones Sally Smith <i>Sally Smith</i>	5/27/19 John Jones Sally Smith <i>Sally Smith</i>

9 Store the sealed Container in a secure location until shipped. The Container is pre-labeled for shipping. Document the shipping of the Container on the Drug Disposal Serialization Tracking Sheet.

DRUG DISPOSAL SERIALIZATION TRACKING SHEET INNER LINER TRACKING FORM					
Name of Collecting Pharmacy		Address of Collecting Pharmacy		Collecting Pharmacy DEA #	
Size of Liner		Address of Reverse Distributor/Disposal Site		Reverse Distributor/Disposal Site DEA #	
1 SERIAL NUMBER	2 Date Liner Acquired (Signature)	3 Date Liner Installed (Name & Signature)	4 Date Removed (Name & Signature)	5 Date Transferred to Storage (Name & Signature)	6 Date Shipped (Name & Signature)
Ex: 32587	4/26/19 <i>Johanna</i>	4/26/19 John Jones Sally Smith <i>Sally Smith</i>	5/26/19 John Jones Sally Smith <i>Sally Smith</i>	5/26/19 John Jones Sally Smith <i>Sally Smith</i>	5/27/19 John Jones Sally Smith <i>Sally Smith</i>



PLEASE NOTE:

Your cardboard container is pre-labeled for shipping. This label is pre-paid with FedEx and must not be copied.

Questions: Contact Consumer Drug Take-Back Client Service Team

take-back@inmar.com

1-800-350-0396 Option 6, Mon-Fri 8am-5pm EST

INSTALLATION INSTRUCTIONS

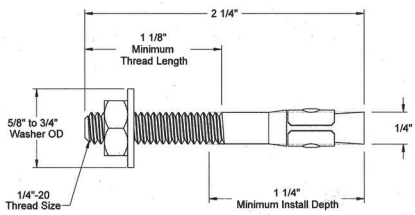
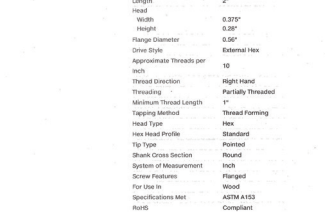
 <p style="text-align: center;">ANCHOR FOR CONCRETE FLOOR</p>	 <p style="text-align: center;">SCREW FOR WOOD FLOOR</p>	<p style="font-size: small;">McMaster-Carr - Flanged Hex Head Screws for Wood, Hot-Dipped Galvanized Steel, 1/4\" data-bbox="345 205 495 215">Page 1 of 2</p> <p style="font-weight: bold; font-size: small;">McMASTER-CARR.</p> <p style="font-size: x-small;">Flanged Hex Head Screws for Wood Hot-Dipped Galvanized Steel, 1/4" Size, 2" Long In stock \$10.09 per pack of 50 95524150</p> <table border="1" style="width: 100%; border-collapse: collapse; font-size: x-small;"> <tr><td>Material</td><td>Hot-Dipped Galvanized Steel</td></tr> <tr><td>Screw Size</td><td>1/4"</td></tr> <tr><td>Screw Size Decimal Equivalent</td><td>0.2500"</td></tr> <tr><td>Length</td><td>2"</td></tr> <tr><td>Head</td><td></td></tr> <tr><td>Width</td><td>0.375"</td></tr> <tr><td>Height</td><td>0.28"</td></tr> <tr><td>Flange Diameter</td><td>0.56"</td></tr> <tr><td>Drive Style</td><td>External Hex</td></tr> <tr><td>Approximate Threads per Inch</td><td>13</td></tr> <tr><td>Thread Direction</td><td>Right Hand</td></tr> <tr><td>Threading</td><td>Partially Threaded</td></tr> <tr><td>Minimum Thread Length</td><td>1"</td></tr> <tr><td>Tapping Method</td><td>Thread Forming</td></tr> <tr><td>Head Type</td><td>Hex</td></tr> <tr><td>Hex Head Profile</td><td>Standard</td></tr> <tr><td>Tip Type</td><td>Pointed</td></tr> <tr><td>Shank Cross Section</td><td>Round</td></tr> <tr><td>System of Measurement</td><td>Inch</td></tr> <tr><td>Screw Features</td><td>Flanged</td></tr> <tr><td>For Use In</td><td>Wood</td></tr> <tr><td>Specifications Met</td><td>ASTM A193</td></tr> <tr><td>RoHS</td><td>Compliant</td></tr> </table> <p style="font-size: x-small;">These steel screws are hot-dipped galvanized to resist corrosion in wet environments and are a good choice for ACO-treated (arsenic-free) lumber. The flange reduces the risk of cracking material and the hex head provides a secure grip with a wrench. They press threads into material for a tight, secure hold. To prevent splitting, drill a pilot hole slightly smaller than the screw. Head height includes the flange. Length is measured from under the head.</p> <p style="font-size: x-small;">McMASTER-CARR Cab PART NUMBER 91578A104 91578A104 Stud Anchor for Concrete © 2016 McMaster-Carr Supply Company</p>	Material	Hot-Dipped Galvanized Steel	Screw Size	1/4"	Screw Size Decimal Equivalent	0.2500"	Length	2"	Head		Width	0.375"	Height	0.28"	Flange Diameter	0.56"	Drive Style	External Hex	Approximate Threads per Inch	13	Thread Direction	Right Hand	Threading	Partially Threaded	Minimum Thread Length	1"	Tapping Method	Thread Forming	Head Type	Hex	Hex Head Profile	Standard	Tip Type	Pointed	Shank Cross Section	Round	System of Measurement	Inch	Screw Features	Flanged	For Use In	Wood	Specifications Met	ASTM A193	RoHS	Compliant	<table border="1" style="width: 100%; border-collapse: collapse; font-size: x-small;"> <tr> <th>DATE</th> <th>SYM</th> <th>REVISIONS RECORD</th> <th>AUTH</th> <th>DR</th> <th>CK</th> </tr> <tr> <td>07/18/2017</td> <td>A</td> <td>RELEASED FOR PRODUCTION</td> <td>WM</td> <td>KQ</td> <td></td> </tr> </table>	DATE	SYM	REVISIONS RECORD	AUTH	DR	CK	07/18/2017	A	RELEASED FOR PRODUCTION	WM	KQ	
Material	Hot-Dipped Galvanized Steel																																																												
Screw Size	1/4"																																																												
Screw Size Decimal Equivalent	0.2500"																																																												
Length	2"																																																												
Head																																																													
Width	0.375"																																																												
Height	0.28"																																																												
Flange Diameter	0.56"																																																												
Drive Style	External Hex																																																												
Approximate Threads per Inch	13																																																												
Thread Direction	Right Hand																																																												
Threading	Partially Threaded																																																												
Minimum Thread Length	1"																																																												
Tapping Method	Thread Forming																																																												
Head Type	Hex																																																												
Hex Head Profile	Standard																																																												
Tip Type	Pointed																																																												
Shank Cross Section	Round																																																												
System of Measurement	Inch																																																												
Screw Features	Flanged																																																												
For Use In	Wood																																																												
Specifications Met	ASTM A193																																																												
RoHS	Compliant																																																												
DATE	SYM	REVISIONS RECORD	AUTH	DR	CK																																																								
07/18/2017	A	RELEASED FOR PRODUCTION	WM	KQ																																																									

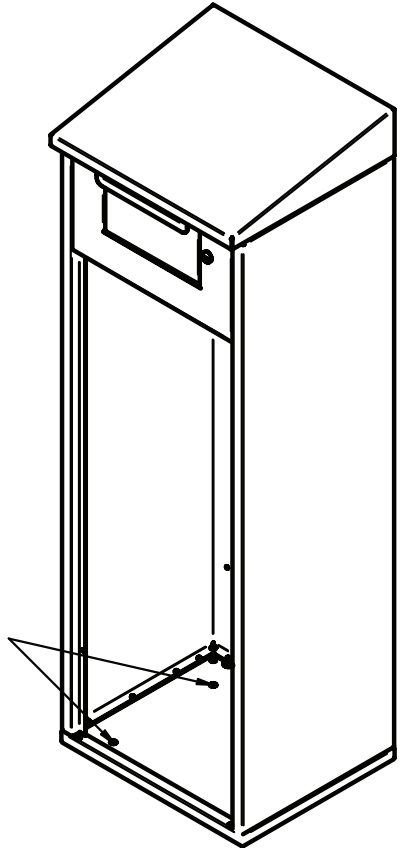

FIGURE 1

INSTALLATION

STEP 1: PLACE CABINET IN PERMANENT LOCATION

STEP 2: USING THE CABINET BASE AS A TEMPLATE, MARK FLOOR USING CLEARANCE HOLES AS SHOWN IN FIGURE 1

STEP 3: DRILL HOLES FOR FLOOR SUBSTRATE

Use four clearance holes in bottom for securing cabinet to floor.

DRUG DISPOSAL SERIALIZATION TRACKING SHEET INNER LINER TRACKING FORM



Serialization Tracking Sheet should be validated by 2 pharmacy employees.

Name of Collecting Pharmacy		Address of Collecting Pharmacy		Collecting Pharmacy DEA #:	
Size of Liner		Address of Reverse Distributor/Disposal Site		Reverse Distributor/Disposal Site DEA #	

1 SERIAL NUMBER	2 Date Liner Acquired (1 Signature)	3 Date Liner Installed (2 Names & Signatures)		4 Date Removed (2 Names & Signatures)		5 Date Transferred to Storage (2 Names & Signatures)		6 Date Shipped (2 Names & Signatures)	
Ex: 32587	4/26/19	4/26/19		5/26/19		5/26/19		5/27/19	
	<i>John Jones</i>	John Jones	<i>John Jones</i>	John Jones	<i>John Jones</i>	John Jones	<i>John Jones</i>	John Jones	<i>John Jones</i>
	<i>John Jones</i>	Sally Smith	<i>Sally Smith</i>	Sally Smith	<i>Sally Smith</i>	Sally Smith	<i>Sally Smith</i>	Sally Smith	<i>Sally Smith</i>

Instructions: Each Inner Liner (container) will bear a permanent, unique identification number to enable tracking on the Inner Liner form. Columns 1 and 2 are to be completed upon receipt of Inner Liner. Column 3 is to be completed upon installation of the container into the collection receptacle. Column 4 is to be completed upon removal of the container from the collection receptacle. Column 5 is to be completed if the Inner Liner is removed from the receptacle and placed in storage before being shipped. Column 6 should be completed when the inner liner is shipped for destruction. Maintain a copy of the completed "Inner Liner form" and other records, as applicable, on file at the collector's registered location for at least 2 years.

The purpose of this form is to document the use of the Inner Liner throughout a collection event. Although proper use of this form is intended to help the collector meet record keeping requirements, requirements may vary based on the registrant location. It is the responsibility of each registered collector to understand and comply with all federal, state and local regulatory requirements pertaining to take-back pharmaceuticals applicable at the collector's registered location. The Inner Liner form is not a DEA Form 41.

Appendix E: Public Outreach Material

Note: All outreach material displays in Appendix E is meant to be a sample of Inmar’s capabilities and intent only, and all material will be updated with appropriate websites, phone numbers, etc. after coordination with other Program Operators for a single system of Promotion is agreed upon and submitted to the Division for final approval.

Sample Education Materials

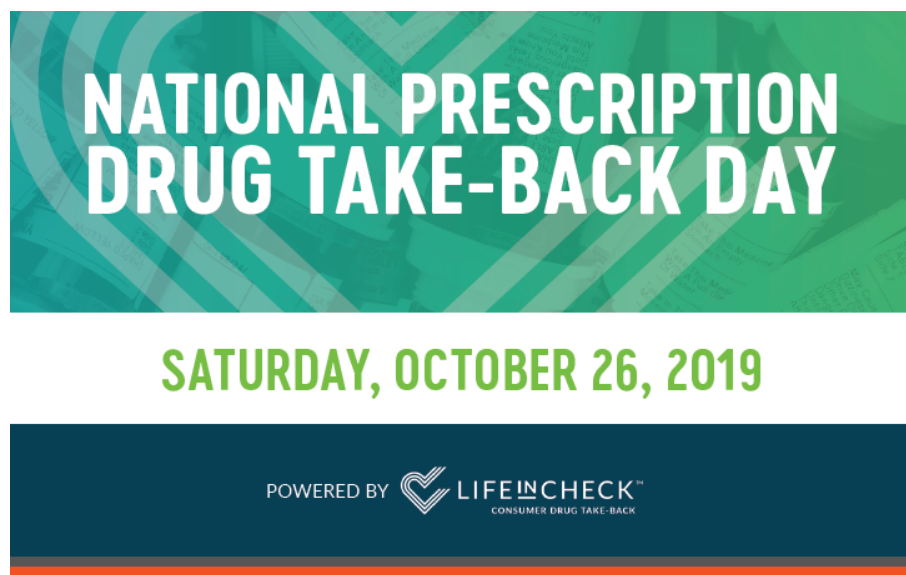

**NATIONAL PRESCRIPTION
DRUG TAKE-BACK DAY**

SATURDAY, OCTOBER 26, 2019

POWERED BY  **LIFE IN CHECK™**
CONSUMER DRUG TAKE-BACK

NATIONAL PRESCRIPTION DRUG TAKE-BACK DAY

- Unused or expired prescription medications are a public safety issue, leading to accidental poisoning, overdose, and abuse.
- Pharmaceutical drugs can be just as dangerous as street drugs when taken without a prescription or a doctor’s supervision.
- The non-medical use of prescription drugs ranks second only to marijuana as the most common form of drug abuse in America.
- The majority of teenagers abusing prescription drugs get them from family and friends and the home medicine cabinet.
- Unused prescription drugs thrown in the trash can be retrieved and abused or illegally sold. Unused drugs that are flushed contaminate the water supply. Proper disposal of unused drugs saves lives and protects the environment.

TAKE-BACK PROGRAMS ARE THE BEST WAY TO DISPOSE OF OLD DRUGS.

But if a program is not available:

- Take the meds out of their bottles;
- Mix the medicines (do not crush tablets or capsules) with an unpalatable substance such as dirt, kitty litter, or used coffee grounds. This prevents thievery or diversion of medicines from the trash.
- Place the mixture in a container such as a zip-lock or sealable plastic bag, and throw the container away in your household trash.

FOR MORE INFORMATION ON PRESCRIPTION DRUG ABUSE, GO TO:

www.dea.gov
www.getsmartaboutdrugs.com
www.justthinktwice.com





LIFE IN CHECK™

EVERY DAY IS CONSUMER
DRUG TAKE-BACK DAY

Working together to protect our
families, communities and environment.

GO TO
[RXDISPOSAL.LIFEINCHECK.COM](https://rxdisposal.lifeincheck.com)
TO FIND A RECEPTACLE NEAR YOU



HOW IT WORKS

- 1** Pull to open drawer
Hale para abrir el cajón
- 2** Place medications inside
Coloque las medicinas adentro
- 3** Close the drawer
Cierre el cajón



LIFE IN CHECK™

**SAFELY DISPOSE OF
YOUR UNUSED OR
EXPIRED MEDICATIONS!**

DID YOU KNOW?

192 AMERICANS

die every day from
a drug overdose.
*cdc.gov

46 MILLION

people at minimum, in 24 major
American metropolitan areas
are exposed to pharmaceutical
contaminated drinking water.

83% OF PEOPLE

who misuse prescription pain
relievers including opioids get them
from a friend, relative or others.
*samhsa.gov

Sample Authorized Collector Marketing Support



**STOP BY TO SAFELY
DISPOSE OF YOUR
UNUSED OR EXPIRED MEDS**

**83% OF PEOPLE WHO MISUSE PRESCRIPTION
PAIN RELIEVERS INCLUDING OPIOIDS GET THEM
FROM A FRIEND, RELATIVE OR OTHERS.**

(WWW.SANMATEO.CA.GOV)

**46 MILLION AMERICANS ARE EXPOSED TO
TRACE AMOUNTS OF MEDICATIONS IN THEIR
DRINKING WATER.**

(ASSOCIATED PRESS)

**SAFELY DISPOSE OF YOUR UNUSED
OR EXPIRED MEDICATIONS HERE**

For more information on safe drug storage and disposal, as well as information on additional collection options, visit rxdisposal.lifeincheck.com or call **1-800-123-4567**

SPONSORED BY 

SOCIAL MEDIA

Twitter: Crafting the Perfect Tweet

Twitter is a simple way to quickly share short pieces of information. Twitter posts can be up to 140 characters in length, but 100 characters is the ideal length for maximum distribution. Including images in your tweets will make them stand out in the Twitter feed; these images should be 1084 x 512 pixels*.

Facebook: Appealing to Your Audience

Facebook allows you to share lengthier posts with slightly larger images. However, longer isn't always better. Shorter posts with compelling graphics tend to receive more shares and comments than longer posts, giving you more visibility within the Facebook news feed. Keeping your Facebook posts under 100 characters is ideal. Always include a link to an article or an image. Images on this social media platform are ideally 1200 x 628 pixels.

SAMPLE POSTS

Copy and paste the following social media posts into your Facebook or Twitter to spread the word about the importance of properly managing leftover pharmaceuticals and drive people to your location. You can also combine them with some of the facts below to drive awareness of the importance of consumer drug take-back programs. Be sure to add one of the accompanying images and to fill in your location's name.

Announcing our new Consumer Drug Take-Back program to safely dispose of unused medications at OUR LOCATION.

OUR LOCATION wants to help you protect your loved ones, the community and the environment! Now you can dispose of unused meds here.

OUR LOCATION wants to help you protect your loved ones, the community and the environment by offering free unused meds disposal.

Got leftover meds? Drop them off at OUR LOCATION – free and easy.

Visit OUR LOCATION to drop off your leftover meds for free – no questions asked.

Leaving leftover drugs in the home can pose health and environmental dangers. Safely dispose of them today at OUR LOCATION!

Drop off your unwanted prescription and OTC meds in the green box at OUR LOCATION.

Rid your home of dangerous, leftover meds today. Bring them to OUR LOCATION to dispose of them safely – no questions asked!

Do you have leftover drugs in your medicine cabinet? Now you can dispose of them easily and safely at OUR LOCATION.

Safe prescription drug disposal is easy. Just find the green box in OUR LOCATION.

Do the right thing: don't flush your meds. Return leftover drugs to a safe take-back location like our green box at OUR LOCATION.

Do the right thing: don't flush your meds. Bring them to OUR LOCATION for proper disposal.

Protect your community – bring your leftover meds to a safe drug take-back program like ours at OUR LOCATION.

Help us stop the opioid epidemic. Dispose of your unused meds at OUR LOCATION.

DID YOU KNOW?
192 AMERICANS
die every day from a drug overdose.*

AT
EVERYDAY IS CONSUMER DRUG TAKE-BACK DAY

Go to rxdisposal.Lifeincheck.com
to find a receptacle near you

*cdc.gov



LIFEINCHECK™

SAFELY DISPOSE OF YOUR UNUSED OR EXPIRED MEDICATIONS!

WE ARE PARTICIPATING!

NATIONAL PRESCRIPTION DRUG TAKE-BACK DAY

SATURDAY, OCTOBER 26, 2019

SPONSORED BY  **LIFEINCHECK™**
CONSUMER DRUG TAKE-BACK

SAMPLE PRESS-RELEASE

Use the template included in the press release folder or copy and paste the below to customize your press release and send out to media outlets in your area.

FOR IMMEDIATE RELEASE

CONTACT:

[Insert contact name here]
[Insert contact's title here]
[Phone number]
[contact or program email address]
[Web site url if you have a web site](#)

[insert pharmacy name] announces convenient drug takeback program for leftover household medications

[CITY, STATE, TODAY'S DATE] -- [PHARMACY NAME] announced today it has established a convenient medication takeback program for easy disposal of leftover, unused and out-of-date prescription and over-the counter medications.

IN AN EFFORT to help reduce the risk of drugs in the home that can potentially harm children, teens or adults, **[PHARMACY NAME]** has set up a secure, safe drop-off location in its pharmacy at **[ADDRESS]** in **[CITY NAME]**.

Unused medications in the home are a source of drug abuse in millions of homes, with the opioid crisis in the United States fueled in part by that availability. More than 83 percent of opioid prescription medications taken by new users are obtained from a friend, relative or others. Overall, 192 Americans die every day from a drug overdose.

"We want to provide the folks in our community with the safe, secure opportunity to clean out their medicine cabinets and make their homes and communities safer," said **[NAME OF PHARMACY MANAGER OR OWNER]**, of **[PHARMACY NAME]**. "We want to remind people that they should not flush drugs down the toilet. Traces of drugs can appear in community drinking water. Our drug disposal unit, which is easily accessible in the pharmacy, is a great answer to that problem and it's simple to do. All they do is just come in, look for the big green receptacle and take it from there. Drugs can be dropped off with no questions asked."

[PHARMACY MANAGER/OWNER'S LAST NAME] said there are some things that can't be taken in the receptacle, such as inhalers and needles, but pharmacy staff will be on hand to help determine what to do. The collection receptacle will be available in the pharmacy at **[ADDRESS]**, **[DAYS AND HOURS]**.

[PHARMACY NAME] partnered with Inmar to manage this drug take back program. The company has a long history as the industry leader in handling prescription and over-the-counter drug returns safely, securely and discreetly for major and regional chain drug stores as well as independent pharmacies and hospitals across the U.S.

Appendix F: Applicable Permits and Licenses

Permits, Licenses and requested enforcement action information is provided on the following pages.

Note: Clean Harbors Permit remains in effect until the DWMRC finishes their renewal. Clean Harbors is expecting the renewal to be complete by March 2023. See below from the current permit:

1.G.2. This permit will expire at 7:00 am Mountain Daylight Time on September 28, 2022. This permit and all conditions herein will remain in force until the effective date of a new permit, if the Permittee has submitted a timely (at least 180 days prior to permit expiration or by an alternative date if requested by the Director), complete application and through no fault of the Permittee, the Director does not issue a new permit with an effective date on or before the expiration date of the previous permit.

DEA REGISTRATION NUMBER	THIS REGISTRATION EXPIRES	FEE PAID
R90571364	04-30-2023	\$1850
SCHEDULES	BUSINESS ACTIVITY	ISSUE DATE
1,2,2N, 3,3N,4,5	REVERSE DISTRIB-COLLECTOR	04-29-2022
123 COMPLIANT LOGISTICS, LLC 2626 N 29TH AVE PHOENIX, AZ 850091602		

CONTROLLED SUBSTANCE REGISTRATION CERTIFICATE
UNITED STATES DEPARTMENT OF JUSTICE
DRUG ENFORCEMENT ADMINISTRATION
WASHINGTON D.C. 20537

Sections 304 and 1008 (21 USC 824 and 958) of the Controlled Substances Act of 1970, as amended, provide that the Attorney General may revoke or suspend a registration to manufacture, distribute, dispense, import or export a controlled substance.

THIS CERTIFICATE IS NOT TRANSFERABLE ON CHANGE OF OWNERSHIP, CONTROL, LOCATION, OR BUSINESS ACTIVITY, AND IT IS NOT VALID AFTER THE EXPIRATION DATE.

CONTROLLED SUBSTANCE REGISTRATION CERTIFICATE
UNITED STATES DEPARTMENT OF JUSTICE
DRUG ENFORCEMENT ADMINISTRATION
WASHINGTON D.C. 20537

DEA REGISTRATION NUMBER	THIS REGISTRATION EXPIRES	FEE PAID
R90571364	04-30-2023	\$1850
SCHEDULES	BUSINESS ACTIVITY	ISSUE DATE
1,2,2N, 3,3N,4,5	REVERSE DISTRIB-COLLECTOR	04-29-2022
123 COMPLIANT LOGISTICS, LLC 2626 N 29TH AVE PHOENIX, AZ 850091602		

Sections 304 and 1008 (21 USC 824 and 958) of the Controlled Substances Act of 1970, as amended, provide that the Attorney General may revoke or suspend a registration to manufacture, distribute, dispense, import or export a controlled substance.

THIS CERTIFICATE IS NOT TRANSFERABLE ON CHANGE OF OWNERSHIP, CONTROL, LOCATION, OR BUSINESS ACTIVITY, AND IT IS NOT VALID AFTER THE EXPIRATION DATE.

DEA REGISTRATION NUMBER	THIS REGISTRATION EXPIRES	FEE PAID
RC0561628	08-31-2023	\$1850
SCHEDULES	BUSINESS ACTIVITY	ISSUE DATE
1,2,2N, 3,3N,4,5	REVERSE DISTRIB-COLLECTOR	07-12-2022
COVANTA ENVIRONMENTAL SOLUTIONS, LLC 2515 S HOLT RD STE 200 INDIANAPOLIS, IN 462415354		

CONTROLLED SUBSTANCE REGISTRATION CERTIFICATE
UNITED STATES DEPARTMENT OF JUSTICE
DRUG ENFORCEMENT ADMINISTRATION
WASHINGTON D.C. 20537

Sections 304 and 1008 (21 USC 824 and 958) of the Controlled Substances Act of 1970, as amended, provide that the Attorney General may revoke or suspend a registration to manufacture, distribute, dispense, import or export a controlled substance.

THIS CERTIFICATE IS NOT TRANSFERABLE ON CHANGE OF OWNERSHIP, CONTROL, LOCATION, OR BUSINESS ACTIVITY, AND IT IS NOT VALID AFTER THE EXPIRATION DATE.

CONTROLLED SUBSTANCE REGISTRATION CERTIFICATE
UNITED STATES DEPARTMENT OF JUSTICE
DRUG ENFORCEMENT ADMINISTRATION
WASHINGTON D.C. 20537

DEA REGISTRATION NUMBER	THIS REGISTRATION EXPIRES	FEE PAID
RC0561628	08-31-2023	\$1850
SCHEDULES	BUSINESS ACTIVITY	ISSUE DATE
1,2,2N, 3,3N,4,5	REVERSE DISTRIB-COLLECTOR	07-12-2022
COVANTA ENVIRONMENTAL SOLUTIONS, LLC 2515 S HOLT RD STE 200 INDIANAPOLIS, IN 462415354		

Sections 304 and 1008 (21 USC 824 and 958) of the Controlled Substances Act of 1970, as amended, provide that the Attorney General may revoke or suspend a registration to manufacture, distribute, dispense, import or export a controlled substance.

THIS CERTIFICATE IS NOT TRANSFERABLE ON CHANGE OF OWNERSHIP, CONTROL, LOCATION, OR BUSINESS ACTIVITY, AND IT IS NOT VALID AFTER THE EXPIRATION DATE.

DEA REGISTRATION NUMBER	THIS REGISTRATION EXPIRES	FEE PAID
RC0561628	08-31-2023	\$1850
SCHEDULES	BUSINESS ACTIVITY	ISSUE DATE
1,2,2N, 3,3N,4,5	REVERSE DISTRIB-COLLECTOR	07-12-2022
COVANTA ENVIRONMENTAL SOLUTIONS, LLC 2515 S HOLT RD STE 200 INDIANAPOLIS, IN 462415354		

CONTROLLED SUBSTANCE/REGULATED CHEMICAL
REGISTRATION CERTIFICATE
UNITED STATES DEPARTMENT OF JUSTICE
DRUG ENFORCEMENT ADMINISTRATION
WASHINGTON D.C. 20537

Sections 304 and 1008 (21 USC 824 and 958) of the Controlled Substances Act of 1970, as amended, provide that the Attorney General may revoke or suspend a registration to manufacture, distribute, dispense, import or export a controlled substance.

THIS CERTIFICATE IS NOT TRANSFERABLE ON CHANGE OF OWNERSHIP, CONTROL, LOCATION, OR BUSINESS ACTIVITY, AND IT IS NOT VALID AFTER THE EXPIRATION DATE.

Form DEA-223/511 (9/2016)

**REPORT
CHANGES
PROMPTLY**

REQUESTING MODIFICATIONS TO YOUR
REGISTRATION CERTIFICATE

To request a change to your registered name, address, the drug schedule or the drug codes you handle, please

1. visit our web site at deaddiversion.usdoj.gov - or
2. call our customer Service Center at **1-(800) 882-9539** - or
3. submit your change(s) in writing to:
**Drug Enforcement Administration
P.O. Box 2639
Springfield, VA 22152-2639**

See Title 21 Code of Federal Regulations, Section 1301.51 for complete instructions.

----- You have been registered to handle the following chemical/drug codes: -----

Drug Codes

9840 9843 9845 9847 9850 1233 1235 1237 1238 1246 1248 1249 1258 1475 1480 1503 1585 1590 2010 2012 2565 2572 6250 7008
7010 7011 7012 7014 7019 7020 7021 7023 7024 7025 7031 7032 7034 7035 7036 7033 7041 7042 7044 7047 7048 7049 7081 7083
7085 9825 9826 9827 9830 9831 9832 9833 9834 9835 9836 9837 9817 9819 9820 9839 9841 9842 9844 9846 9848 9851 9852 9853
9854 9855 9856 9609 9611 9612 9613 9615 9616 9617 9618 9619 9621 9622 9623 9624 9625 9626 9627 9628 9629 9631 9632 9633
9634 9635 9636 9637 9638 9641 9642 9643 9644 9645 9646 9647 9649 9661 9663 9750 9811 9812 9813 9814 9815 9816 9821 9822
9823 9824 7089 7104 7118 7122 7144 7173 7200 7201 7203 7221 7222 7225 7249 7260 7297 7298 7315 7348 7350 7360 7370 7374
7381 7385 7390 7391 7392 7395 7396 7398 7399 7400 7401 7402 7404 7405 7411 7415 7431 7432 7433 7434 7435 7437 7438 7439
7455 7458 7470 7473 7482 7484 7493 7498 7508 7509 7517 7518 7519 7521 7524 7532 7535 7536 7537 7538 7540 7541 7542 7543
7545 7546 7694 9051 9052 9053 9054 9055 9056 9070 9145 9168 9200 9301 9302 9304 9305 9306 9307 9308 9309 9312 9313 9314
9315 9319 9335 9547 9551 9560 9601 9602 9603 9604 9605 9606 9607 9608 9098 9614 7446 7547 9838 7245 7443 7544 7548 7246
1245 1595 7043 7286 9751 9756 9757 9758 9759 9764 9765

DEA REGISTRATION NUMBER	THIS REGISTRATION EXPIRES	FEE PAID
RC0322595	08-31-2023	\$1850
SCHEDULES	BUSINESS ACTIVITY	ISSUE DATE
1,2,2N, 3,3N,4,5	REVERSE DISTRIB-COLLECTOR	07-20-2022
CHESAPEAKE WASTE SOLUTIONS 190 SHELLYLAND RD MANHEIM, PA 175458679		

CONTROLLED SUBSTANCE REGISTRATION CERTIFICATE
UNITED STATES DEPARTMENT OF JUSTICE
DRUG ENFORCEMENT ADMINISTRATION
WASHINGTON D.C. 20537

Sections 304 and 1008 (21 USC 824 and 958) of the Controlled Substances Act of 1970, as amended, provide that the Attorney General may revoke or suspend a registration to manufacture, distribute, dispense, import or export a controlled substance.

THIS CERTIFICATE IS NOT TRANSFERABLE ON CHANGE OF OWNERSHIP, CONTROL, LOCATION, OR BUSINESS ACTIVITY, AND IT IS NOT VALID AFTER THE EXPIRATION DATE.

CONTROLLED SUBSTANCE REGISTRATION CERTIFICATE
UNITED STATES DEPARTMENT OF JUSTICE
DRUG ENFORCEMENT ADMINISTRATION
WASHINGTON D.C. 20537

DEA REGISTRATION NUMBER	THIS REGISTRATION EXPIRES	FEE PAID
RC0322595	08-31-2023	\$1850
SCHEDULES	BUSINESS ACTIVITY	ISSUE DATE
1,2,2N, 3,3N,4,5	REVERSE DISTRIB-COLLECTOR	07-20-2022
CHESAPEAKE WASTE SOLUTIONS 190 SHELLYLAND RD MANHEIM, PA 175458679		

Sections 304 and 1008 (21 USC 824 and 958) of the Controlled Substances Act of 1970, as amended, provide that the Attorney General may revoke or suspend a registration to manufacture, distribute, dispense, import or export a controlled substance.

THIS CERTIFICATE IS NOT TRANSFERABLE ON CHANGE OF OWNERSHIP, CONTROL, LOCATION, OR BUSINESS ACTIVITY, AND IT IS NOT VALID AFTER THE EXPIRATION DATE.

DEA REGISTRATION NUMBER	THIS REGISTRATION EXPIRES	FEE PAID
RC0322595	08-31-2023	\$1850
SCHEDULES	BUSINESS ACTIVITY	ISSUE DATE
1,2,2N, 3,3N,4,5	REVERSE DISTRIB-COLLECTOR	07-20-2022
CHESAPEAKE WASTE SOLUTIONS 190 SHELLYLAND RD MANHEIM, PA 175458679		

CONTROLLED SUBSTANCE/REGULATED CHEMICAL
REGISTRATION CERTIFICATE
UNITED STATES DEPARTMENT OF JUSTICE
DRUG ENFORCEMENT ADMINISTRATION
WASHINGTON D.C. 20537

Sections 304 and 1008 (21 USC 824 and 958) of the Controlled Substances Act of 1970, as amended, provide that the Attorney General may revoke or suspend a registration to manufacture, distribute, dispense, import or export a controlled substance.

THIS CERTIFICATE IS NOT TRANSFERABLE ON CHANGE OF OWNERSHIP, CONTROL, LOCATION, OR BUSINESS ACTIVITY, AND IT IS NOT VALID AFTER THE EXPIRATION DATE.

Form DEA-223/511 (9/2016)



**REPORT
CHANGES
PROMPTLY**

REQUESTING MODIFICATIONS TO YOUR
REGISTRATION CERTIFICATE

To request a change to your registered name, address, the drug schedule or the drug codes you handle, please

1. visit our web site at deaddiversion.usdoj.gov - or
2. call our customer Service Center at 1-(800) 882-9539 - or
3. submit your change(s) in writing to:
**Drug Enforcement Administration
P.O. Box 2639
Springfield, VA 22152-2639**

See Title 21 Code of Federal Regulations, Section 1301.51 for complete instructions.

----- You have been registered to handle the following chemical/drug codes: -----

Drug Codes

7432 7439 9304 7376 7401 7437 9602 9606 9609 9613 2010 7360 7370 7402 7404 9055 9301 9308 1235 7368 7411 9070 9314 9601
7364 7390 7400 7405 7493 9145 9319 9604 9611 1480 2565 7378 7396 7438 7455 7484 7315 7316 7328 7372 7373 7433 7435 7458
7470 9168 9200 9302 9305 9309 9312 9315 9607 9608 9612 1475 7366 9056 9335 9605 1503 1585 2572 7260 7340 7371 7395 7456
9051 9052 9053 9054 9306 9313 9603 7173 7200 7297 7298 7375 7381 7415 7434 7436 7461 7469 7118 9827 9830 9831 9832 9833
9834 9835 9836 9837 7509 7517 7518 7519 7521 7524 7532 7535 7536 7537 9623 7538 7540 7541 9624 7542 7543 7544 7546 7545
7547 7548 7694 9098 9307 9547 9551 9560 9614 9615 9616 9617 9618 9619 9621 9622 9637 9625 9626 9627 9628 9629 9631 9632
9633 9634 9635 9636 9638 9641 7041 9642 9643 9644 9645 9646 9647 9820 9649 9661 9663 9750 9811 9812 9813 9814 9815 9816
9817 9819 7034 7035 7036 7042 7044 7047 7221 7048 7049 7081 7083 7085 7089 7104 7122 7144 1237 1238 1246 1248 1249 1258
1590 2012 6250 7008 7010 7011 7012 7014 7019 7020 7021 7023 7024 7025 7031 7032 7033 9838 9839 9840 9841 9842 9843 9844
9845 9846 9847 9848 9850 9851 9852 9853 9854 9855 9856 9821 9822 9823 9824 9825 9826 7201 7203 7222 7508 7225 7245 7246
7249 7348 7350 7374 7385 7391 7392 7398 7399 7431 7443 7446 7473 7482 7498 1233 1245 1595 7043 7286 9751 9756 9757 9758
9759 9764 9765



UNITED STATES ENVIRONMENTAL PROTECTION AGENCY
REGION 5
77 WEST JACKSON BOULEVARD
CHICAGO, IL 60604-3590

APR 23 2014

Mr. James N. Larson
President
Ross Incineration Services, Inc.
36790 Giles Road
Grafton, Ohio 44044

REPLY TO THE ATTENTION OF:

Re: Final Federal RCRA Permit, Ross Incineration Services, Inc.
36790 Giles Road, Grafton, Ohio 44044
OHD 048 415 665

Dear Mr. Larson:

Enclosed is a copy of the federal portion of a Resource Conservation and Recovery Act (RCRA) Hazardous Waste permit for the above-referenced facility. The complete RCRA Hazardous Waste permit for the facility contains both federal permit conditions (contained herein) and State permit conditions which were issued separately by the State of Ohio RCRA program authorized under Title 40 of the Code of Federal Regulations (40 C.F.R.), Part 271. Any hazardous waste activity not included in the federal portion of the RCRA permit or in the State portion of the RCRA permit is prohibited when such activity requires a RCRA Hazardous Waste permit.

You may appeal the issuance of this permit by filing a petition for review with the Environmental Appeals Board (EAB).

A petition for review of any condition of a RCRA permit decision must be filed with the EAB within 30 days after the U.S. Environmental Protection Agency serves notice of the issuance of the final permit decision. *See* 40 C.F.R. § 124.19(a)(3). When EPA serves the notice by mail, service is deemed to be completed when the notice is placed in the mail, not when it is received. However, to compensate for the delay caused by mailing, the 30-day deadline for filing a petition is extended by three days if the final permit decision being appealed was served on the petitioner by mail. *See* 40 C.F.R. § 124.20(d). Petitions are deemed filed when they are received by the Clerk of the Board at the address specified for the appropriate method of delivery. *See* 40 C.F.R. § 124.19(a)(3) and 40 C.F.R. § 124.19(i). Additional information regarding petitions for review may be found in the Environmental Appeals Board Practice Manual (January 2013) and A Citizen's Guide to EPA's Environmental Appeals Board, both of which are available at: http://yosemite.epa.gov/oa/EAB_Web_Docket.nsf/General+Information/Environmental+Appeals+Board+Guidance+Documents?OpenDocument.

Eligibility to appeal a federal permit is set forth at 40 C.F.R. § 124.19. General filing requirements are contained in "The Environmental Appeals Board Practice Manual," and "A Citizens' Guide to EPA's Environmental Appeals Board."

All documents that are sent to the EAB through the U.S. Postal Service (except by Express Mail) must be addressed as follows:

Clerk of the Board
U.S. Environmental Protection Agency
Environmental Appeals Board
1200 Pennsylvania Avenue, NW (Mail Code 1103M)
Washington, DC 20460-0001

Documents that are hand-carried in person, delivered via courier, mailed by Express Mail, or delivered by a non-U.S. Postal Service carrier (e.g., Federal Express or UPS) must be delivered to the EAB at:

Clerk of the Board
U.S. Environmental Protection Agency
Environmental Appeals Board
1201 Constitution Avenue, NW
U.S. EPA East Building, Room 3332
Washington, DC 20004

You should also send a copy of the petition to:

RCRA Branch (LR-8J)
U.S. Environmental Protection Agency, Region 5
77 West Jackson Boulevard
Chicago, Illinois 60604-3590

The administrative procedures for filing an appeal are found in 40 C.F.R. § 124.19. The administrative appeal procedures must be completed prior to any action seeking judicial review.

This federal permit is effective May 23, 2014 and is valid until January 29, 2024, unless the federal permit is revoked and reissued, or terminated pursuant to 40 C.F.R. §§ 270.41 and 270.43. Failure to comply with any conditions of the federal permit may result in civil and/or criminal penalties.

If you have any questions concerning this permit, please contact Mr. Jae Lee of my staff, at (312) 886-3781.

Sincerely,



Margaret M. Guerriero
Director
Land and Chemicals Division

cc: Jeremy Carroll, OEPA

FINAL

**UNITED STATES ENVIRONMENTAL PROTECTION AGENCY
REGION 5**

RESOURCE CONSERVATION AND RECOVERY ACT PERMIT

Facility Name and Location: Ross Incineration Services, Inc.
36790 Giles Road
Grafton, Ohio 44044

Owner: Ross Incineration Services, Inc.
36790 Giles Road
Grafton, Ohio 44044

Operator: Ross Incineration Services, Inc.
36790 Giles Road
Grafton, Ohio 44044

U.S. EPA Identification Number: OHD 048 415 665

Effective Date: May 23, 2014

Expiration Date: January 29, 2024

Authorized Activities:

The U. S. Environmental Protection Agency hereby issues a Resource Conservation and Recovery Act permit (hereinafter referred to as "this permit") to Ross Incineration Services Inc. (hereinafter referred to as "you" or "the permittee") in connection with the hazardous waste management operations at Ross Incineration Services, Inc., in Grafton, Ohio.

This permit is issued under the Solid Waste Disposal Act, as amended by the Resource Conservation and Recovery Act of 1976, and the Hazardous and Solid Waste Amendments ("HSWA") of 1984 (42 U.S.C. § 6901 *et seq.*) (collectively referred to as "RCRA") and EPA's regulations promulgated thereunder (codified, and to be codified, in Title 40 of the Code of Federal Regulations ("40 C.F.R.")).

The "RCRA permit" consists of both this permit, which contains the effective federal RCRA permit conditions, and the effective state RCRA permit conditions issued by the state of Ohio's RCRA program authorized under 40 C.F.R. Part 271 (hereinafter called the "state RCRA permit").

The state RCRA permit was issued on January 29, 2014. The effective and expiration dates of the state RCRA permit are January 29, 2014 and January 29, 2024, respectively. Any hazardous waste activity which requires a RCRA permit and is not included in the RCRA permit is prohibited.

Permit Approval:

On June 28, 1989, the state of Ohio received final authorization according to Section 3006 of RCRA, 42 U.S.C. § 6926, and 40 C.F.R. Part 271, to administer the pre-HSWA RCRA hazardous waste program. The state of Ohio also received final authorization to administer certain additional RCRA requirements on several occasions since then.

However, because EPA has not yet authorized the state of Ohio to administer certain regulations, including the air emission standards for tanks and containers, EPA is issuing the RCRA permit requirements for operations at your facility which fall under these regulations.

You must comply with all terms and conditions contained in this permit. This permit consists of all conditions contained herein; the documents attached hereto; all documents cross-referenced in these documents; approved submittals (including plans, schedules and other documents); applicable regulations in 40 C.F.R. Parts 124, 260, 261, 262, 264, 265, 268 and 270; and applicable provisions of RCRA.

This permit is based on the assumption that the information submitted in your RCRA Part B Permit Application on April 1, 2013, and all other modifications to that application (hereinafter referred to as the "Part B Permit Application") is accurate, and the facility is configured, operated and maintained as specified in the Part B Permit Application and other relevant documents.

Any inaccuracies in the submitted information may be grounds for EPA to terminate, revoke and reissue, or modify this permit in accordance with 40 C.F.R. §§ 270.41, 270.42 and 270.43; and for enforcement action. You must inform EPA of any deviation from, or changes in, the information in the Part B Permit Application and other pertinent documents that might affect your ability to comply with the applicable regulations or conditions of this permit.

Opportunity to Appeal:

Petitions for review must be submitted within 30 days after EPA serves notice of the final permit decision. Any person who filed comments on the draft permit or participated in the public hearing may petition the Environmental Appeals Board to review any condition of the permit decision. Any person who failed to file comments or failed to participate in the public hearing on the draft permit may file a petition for review

Final April 2014

Ross Incineration Services, Inc.

OHD 048 415 665

only to the extent of the changes from the draft to the final permit decision. The procedures for permit appeals are found in 40 C.F.R. § 124.19.

Effective Date:

This permit is effective as of May 23, 2014 and will remain in effect until January 29, 2024 unless revoked and reissued under 40 C.F.R. § 270.41, terminated under 40 C.F.R. § 270.43, or continued in accordance with 40 C.F.R. § 270.51(a).

By:



Margaret M. Guerriero, Director
Land and Chemicals Division

Date:

4/23/2014

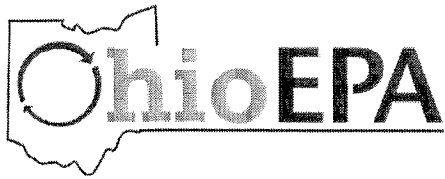

John R. Kasich, Governor
Mary Taylor, Lt. Governor
Craig W. Butler, Interim Director

CERTIFIED MAIL

January 29, 2014

Ross Incineration Services, Inc.
Attn: Mr. James N. Larson
36790 Giles Road
Grafton, OH 44044

RE: Ross Incineration Services, Inc.
Permit Renewal
Hazardous Waste
Lorain County
OHD048415665

Dear Mr. Larson:

Here is the renewed Ohio Hazardous Waste Facility Installation and Operation Permit (Permit) for Ross Incineration Services, Inc. I have also enclosed a copy of the Response to Comments Ohio EPA prepared in response to written comments the Agency received concerning the Part B permit application. The Permit is effective today, January 29, 2014. The date-stamped, page-numbered copy of the Part B permit application is also enclosed.

You are hereby notified that this action of the Director is final and may be appealed to the Environmental Review Appeals Commission pursuant to Section 3745.04 of the Ohio Revised Code. The appeal must be in writing and set forth the action complained of and the grounds upon which the appeal is based. The appeal must be filed with the Commission within thirty (30) days after notice of the Director's action. The appeal must be accompanied by a filing fee of \$70.00 which the Commission, in its discretion, may reduce if by affidavit you demonstrate that payment of the full amount of the fee would cause extreme hardship. Notice of the filing of the appeal shall be filed with the Director within three (3) days of filing with the Commission. Ohio EPA requests that a copy of the appeal be served upon the Ohio Attorney General's Office, Environmental Enforcement Section. An appeal may be filed with the Environmental Review Appeals Commission at the following address:

Environmental Review Appeals Commission
77 South High Street, 17th Floor
Columbus, OH 43215

Mr. James N. Larson
Ross Incineration Services, Inc.
Page 2

If you have any questions concerning compliance, please contact Neil Wasilk of Ohio EPA's Northeast District Office at (330) 963-1200.

Sincerely,

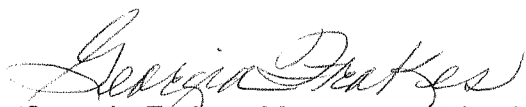

Georgia Frakes, Management Analyst
Division of Materials and Waste Management

Attachments

cc: John Nyers, DMWM, CO
Scott Hester, DMWM, CO
Devan Wolfe, DMWM, CO
Laura Morgan, DMWM, CO
Ed Lim, DERR, CO
Ed Lim, DERR, CO
Todd Anderson, Legal
Heidi Griesmer, PIC
Neil Wasilk, DMWM, NEDO
John Paquelet, DMWM, NEDO
Nyll McKenna, DMWM, NEDO
Harry Courtright, DERR, CO
Jae Lee, Region V, US EPA

OHIO ENVIRONMENTAL PROTECTION AGENCY

OHIO E.P.A.

OHIO HAZARDOUS WASTE FACILITY
INSTALLATION AND OPERATION PERMIT RENEWAL

JAN 29 2014

ENTERED DIRECTOR'S JOURNAL

Permittee: Ross Incineration Services, Inc.

Mailing Address: Ross Incineration Services, Inc.
36790 Giles Road
Grafton, OH 44044

Owner: Ross Incineration Services, Inc.
36790 Giles Road
Grafton, OH 44044

Ross Consolidated Corp.
36790 Giles Road
Grafton, OH 44044

Operator: Ross Incineration Services, Inc.
36790 Giles Road
Grafton, OH 44044

Location: Ross Incineration Services, Inc.
36790 Giles Road
Grafton, OH 44044

US EPA ID:	OHD 048 415 665
Issue Date:	January 29, 2014
Effective Date:	January 29, 2014
Expiration Date:	January 29, 2024

AUTHORIZED ACTIVITIES

In reference to the application of Ross Incineration Services, Inc. for an Ohio Hazardous Waste Facility Installation and Operation Renewal Permit under Ohio Revised Code (ORC) Chapter 3734 and the record in this matter, you are authorized to conduct at the above-named facility the following hazardous waste management activities:

- Incineration of hazardous waste;
- Storage of hazardous waste in tanks and containers;
- Treatment of hazardous waste in tanks and a filter press;
- Post-Closure;
- Corrective Action

PERMIT APPROVAL

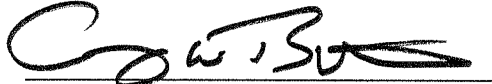

Craig W. Butler, Interim Director
Ohio Environmental Protection Agency

This permit approval is based upon the record in this matter which is maintained at the offices of the Ohio Environmental Protection Agency. The Director has considered the application, accompanying information, inspection reports of the facility, a report regarding the facility's compliance or noncompliance with the terms and conditions of its permit and rules adopted by the Director under this chapter, and such other information as is relevant to the operation of the facility. The Director has determined that the facility under the existing permit has a history of compliance with ORC Chapter 3734, rules adopted under it, the existing permit, or orders entered to enforce such requirements that demonstrate sufficient reliability, expertise, and competency to operate the facility henceforth under this chapter, rules adopted under it, and the renewal permit.

Entered into the Journal of the Director this 29th day of January, 2014.

By Donna Cassiter of the Ohio Environmental Protection Agency.

I certify this to be a true and accurate copy of the official documents as filed in the records of the Ohio Environmental Protection Agency.

By: Donna Cassiter Date: 1-29-14

SK File



Modified Ohio Hazardous Waste Facility Installation and Operation Permit

Division of Materials and Waste Management

Permittee: Ross Incineration Services, Inc. U.S. EPA ID: OHD048415665

Facility Name: Ross Incineration Services, Inc.

Mailing Address: 36790 Giles Road

City: Grafton State: OH Zip: 44044

Operator Name: Ross Incineration Services, Inc.

Mailing Address: 36790 Giles Road

City: Grafton State: OH Zip: 44044

Facility Street Address: 36790 Giles Road

City: Grafton State: OH Zip: 44044

Permit Modification

This Modified Ohio Hazardous Waste Facility Installation and Operation Permit is issued pursuant and subject to Section 3734.05(I) of the Ohio Revised Code and Rule 3745-50-51(D) of the Ohio Administrative Code.

The Ohio Hazardous Waste Facility Installation and Operation Permit for the facility with the above-referenced ID number as issued by the Ohio Environmental Protection Agency and journalized on January 29, 2014, is hereby incorporated by reference in its entirety, except as it may be modified herein. This modification of the permit shall remain in effect until such time as the Ohio Hazardous Waste Facility Installation and Operation Permit is renewed, modified, withdrawn, suspended, or revoked.

The Permittee shall comply with all requirements of the modified permit application as amended or supplemented on May 29, 2014 and August 15, 2014, September 12, 2014, and October 6, 2014. The information contained in the modified permit application is incorporated herein by reference. Specifically, all written statements regarding the specifications, locations, or capabilities of the processes, equipment, containment devices, safety devices or programs, or other matters made by the applicant in the permit modification application are hereby incorporated as express, binding terms and conditions of this modified permit.

The modified Terms and Conditions of this permit are attached hereto and are incorporated herein by reference. The modified Terms and Conditions supersede and replace the corresponding pages found in the January 29, 2014 renewal permit.

Permit Modification Approval

Entered into the Journal of the Director on:

5/28/15

Date:

Craig W. Butler, Director
Ohio Environmental Protection Agency





Final Title V Permit
Ross Incineration Services, Inc.
Permit Number: P0108010
Facility ID: 0247050278
Effective Date: 2/26/2019

Authorization

Facility ID: 0247050278
Facility Description: Treatment, Storage, Disposal Facility for Hazardous Waste
Application Number(s): A0016024, A0016023, A0016026, A0016025, A0044385
Permit Number: P0108010
Permit Description: Title V renewal permit for a commercial hazardous waste incinerator with storage tanks, cooling towers and related operations.
Permit Type: Renewal
Issue Date: 2/5/2019
Effective Date: 2/26/2019
Expiration Date: 2/26/2024
Superseded Permit Number: P0085374

This document constitutes issuance of an OAC Chapter 3745-77 Title V permit to:

Ross Incineration Services, Inc.
36790 Giles Road
Grafton, OH 44044-9752

Ohio Environmental Protection Agency (EPA) District Office or local air agency responsible for processing and administering your permit:

Ohio EPA DAPC, Northeast District Office
2110 East Aurora Rd.
Twinsburg, OH 44087
(330)963-1200

The above named entity is hereby granted a Title V permit pursuant to Chapter 3745-77 of the Ohio Administrative Code. This permit and the authorization to operate the air contaminant sources (emissions units) at this facility shall expire at midnight on the expiration date shown above. You will be sent a notice approximately 18 months prior to the expiration date regarding the renewal of this permit. If you do not receive a notice, please contact the Ohio EPA DAPC, Northeast District Office. If a renewal permit is not issued prior to the expiration date, the permittee may continue to operate pursuant to OAC rule 3745-77-08(E) and in accordance with the terms of this permit beyond the expiration date, if a timely renewal application is submitted. A renewal application will be considered timely if it is submitted no earlier than 18 months and no later than 6 months prior to the expiration date.

This permit is granted subject to the conditions attached hereto.

Ohio Environmental Protection Agency

A handwritten signature in black ink that reads "Laurie A. Stevenson". The signature is written in a cursive, flowing style.

Laurie A. Stevenson
Director



Mike DeWine, Governor
Jon Husted, Lt. Governor
Laurie A. Stevenson, Director

September 15, 2022

Ross Incineration Services, Inc.
Susan Kaiser
36790 Giles Rd
Grafton OH 44044

Re: Approval Under Ohio EPA National Pollutant Discharge Elimination System (NPDES) – Industrial Stormwater General Permit – OHR000007

Dear Applicant,

Your NPDES Notice of Intent (NOI) application is approved for the following facility/site. Please use your Ohio EPA Facility Permit Number in all future correspondence.

Facility Name:	Ross Incineration Services Inc
Facility Location:	36790 Giles Rd
City:	Grafton
County:	Lorain
Township:	Eaton
Ohio EPA Facility Permit Number:	3GR00309*GG
Permit Effective Date:	September 15, 2022
Permit Expiration Date:	May 31, 2027

Please read and review the permit carefully. The permit contains requirements and prohibitions with which you must comply. A copy of the general permit may be viewed or downloaded from [here](#). Coverage under this permit will remain in effect until a renewal of the permit is issued by the Ohio EPA.

If you need assistance or have questions, please call (614) 644-2001 and ask for Industrial Stormwater General Permit support or visit our website at epa.ohio.gov.

Sincerely,

A handwritten signature in black ink that reads "Laurie A. Stevenson".

Laurie A. Stevenson
Director

Note: Clean Harbors Permit remains in effect until the DWMRC finishes their renewal. Clean Harbors is expecting the renewal to be complete by March 2023. See below from the current permit:

1.G.2. This permit will expire at 7:00 am Mountain Daylight Time on September 28,

2022. This permit and all conditions herein will remain in force until the effective

date of a new permit, if the Permittee has submitted a timely (at least 180 days

prior to permit expiration or by an alternative date if requested by the Director),

complete application and through no fault of the Permittee, the Director does not

issue a new permit with an effective date on or before the expiration date of the

previous permit.

STATE OF UTAH PLAN APPROVAL

Effective Date: September 28, 2012

PERMITTEE:

Clean Harbors Aragonite, LLC
Tooele County, Utah
EPA Identification Number UTD981552177

Pursuant to the Utah Solid and Hazardous Waste Act, 19-6-101, et. seq., Utah Code Annotated 1953, as amended, and the regulations promulgated thereunder by the Utah Solid and Hazardous Waste Control Board, codified in the Utah Administrative Code R315, and pursuant to the Solid Waste Disposal Act, 42 U.S.C. 3251 et. seq., as amended by the Resource Conservation and Recovery Act of 1976, 42 U.S.C. 6901 et. seq., and the Hazardous and Solid Waste Amendments of 1984 (HSWA), a plan approval (hereinafter called a permit), is issued to Clean Harbors Aragonite, LLC (hereinafter referred to as the Permittee), to operate a hazardous waste treatment, storage, and transfer facility located approximately 2.5 miles south of Interstate 80 at the Aragonite exit, Exit #56, Tooele County, Utah, latitude 40° 44' 004" North and longitude 112° 58' 005" West.

The Permittee shall comply with all the terms and conditions of this permit. The permit consists of Modules 1 through 5 and Attachments 1 through 17. The Permittee shall also comply with all applicable State rules, including R315-1 through R315-9, R315-12 through R315-14, R315-16, R315-50, and R315-101.

Applicable rules are those which are in effect on the date of issuance of this permit and any self-implementing provisions and related rules which, according to the requirements of HSWA, are automatically applicable to the Permittee's hazardous waste management activities, notwithstanding the conditions of this permit.

This permit is based on the premise that the information submitted in the original permit application, dated July 22, 1987, as modified by subsequent amendments, permit modification requests received throughout the term of the original permit, the permit renewal application received February 1, 1999, as modified by the submission of subsequent amendments, permit modification requests received throughout the term of the initial permit renewal, and the permit renewal application received December 14, 2009, is accurate. The Permittee's failure in the application or during the permit issuance process to disclose fully all relevant facts, or the Permittee's misrepresentation of any relevant facts at any time, shall be cause for the termination or modification of this permit, the initiation of enforcement action, including criminal proceedings, or any combination of these remedies. The Permittee shall inform the Director of the Division of Solid and Hazardous Waste of any deviation from or changes in the information on which the application was based which would affect the Permittee's ability to comply with the terms and conditions of this permit. The Director will enforce all terms and conditions of this permit. Any challenges to any condition of this permit shall be appealed in accordance with the applicable provisions of the Utah Code Annotated.

This permit is effective as of September 28, 2012, at 7:00 a.m., MDT, and shall remain in effect until 7:00 a.m. MDT, September 28, 2022, unless revoked and reissued pursuant to R315-3-4.2, terminated pursuant to R315-3-4.4, or continued in accordance with R315-3-5.2 and the conditions of this permit.

Signature: 

Scott T. Anderson, Director
Division of Solid and Hazardous Waste

Date: 9/27/12

**STATE OF ARKANSAS
ARKANSAS DEPARTMENT OF ENVIRONMENTAL
QUALITY**



Final

RCRA HAZARDOUS WASTE PERMIT 10H-RN2

Clean Harbors
El Dorado, Union County, Arkansas

May 2019

ARKANSAS DEPARTMENT OF ENVIRONMENTAL QUALITY
PERMIT
FOR A HAZARDOUS WASTE MANAGEMENT FACILITY

PERMITTEE: Clean Harbors El Dorado, LLC
OWNER: Clean Harbors El Dorado, LLC
OPERATOR: Clean Harbors El Dorado, LLC
FACILITY LOCATION: El Dorado, Union County, Arkansas
EPA I. D. NUMBER: ARD069748192
ACTIVITY: Commercial Hazardous Waste Management facility primarily engaged in the incineration of hazardous wastes and the reclamation and recovery of ferrous metals and calcium chloride (CaCl₂) products
PERMIT NUMBER: 10H-RN2
AFIN: 70-00098

Pursuant to the Federal Solid Waste Disposal Act, as amended by the Resource Conservation and Recovery Act of 1976 (RCRA), as amended (42 USC 6901 et seq.), the Hazardous and Solid Waste Amendments of 1984 (HSWA), the Arkansas Hazardous Waste Management Act (Arkansas Code Annotated §8-7-201 *et seq.*), as amended, the Arkansas Remedial Action Trust Fund Act (A.C.A. §8-7-501 *et seq.*), as amended, and the Arkansas Pollution Control and Ecology Commission (APC&EC) Regulation No. 23, a permit is issued by the Arkansas Department of Environmental Quality (ADEQ) to Clean Harbors El Dorado (Permittee), to operate a hazardous waste management facility located in Union County, near El Dorado, Arkansas. APC&EC Regulation No. 23, as adopted, September 25, 2015 and effective October 18, 2015, has incorporated verbatim all applicable hazardous waste federal regulations formerly cited in permits by "40 CFR" part number but now cited by the equivalent APC&EC Regulation No. 23 section number, unless specifically noted otherwise.

The Permittee's location is summarily described as follows:

309 American Circle, El Dorado, Union County, Arkansas
Latitude 33°12'22.5"N, Longitude 92°37'47.5"W

The Permittee shall comply with all terms and conditions of this permit. This permit consists of the conditions contained in APC&EC Regulation No. 23, §§ 260 through 266, 268, 270, 273, and 279 and 40 C.F.R. § 124, as specified in the permit. Applicable regulations are those which are

in effect on the date of issuance of the Permit, in accordance with APC&EC Regulation No. 23 §270.32(c). Nothing contained herein shall negate Permittee's duty to comply with the regulations and this permit, or ADEQ's ability to enforce the regulations and this permit. This permit is based on the assumption that the information submitted in the Part B Permit Application of September 15, 2017, revised on February 22, 2018 and then on April 6, 2018 (hereafter referred to as the Part B Application), is accurate, and the facility will be operated as specified in the Part B Application and this permit.

Any inaccuracies found in the submitted information may be grounds for the termination, revocation, and reissuance, or modification of this permit in accordance with APC&EC Regulation No. 23 §§270.41 and 270.43 and for enforcement action. The Permittee shall inform ADEQ of any deviation from or changes in the information in the Part B Application which would affect the Permittee's ability to comply with the permit or applicable regulations.

The Director reserves the right to amend or add conditions to this permit, as necessary to be protective of human health and the environment pursuant to APC&EC Regulation No. 23 §270.32(b)(2).

This permit, which incorporates Modules I, II, III, IV, VII, XII(a), XII(b), XIII, XIV, and XV as conditions herein, shall be effective upon service of notice of the permit decision, as stipulated in APC&EC Regulation No. 8.211(B) (Administrative Procedures), and shall remain in effect for a period of ten (10) years from the effective date unless revoked and reissued under APC&EC Regulation No. 23 §270.41, terminated under APC&EC Regulation No. 23 §270.43, continued in accordance with §270.51(a) and §270.51(d), or modified under §270.41. This permit supersedes any Memorandum of Understandings (MOUs) between the Permittee and ADEQ prior to the effective date of this permit Renewal Application.

For the purposes of resolving conflicts between requirements to which Permittee is subject, the following hierarchy and order of authority will govern in Permittee's duty to comply: i) Regulations promulgated under APC&EC Regulation No. 23; ii) General Permit Conditions (Module I); iii) General Facility Conditions (Module II); iv) Conditions and/or standards specific to activity (Modules III, IV, VII, XII(a), XII(b), XIII, and XIV of the permit application).

Issued this 26th day of June, 2018



Kevin White, Associate Director

Office of Land Resources

Arkansas Department of Environmental Quality

Right to Adjudicatory Hearing:

This final permitting decision may be appealed by filing a written Request for Commission Review and Adjudicatory Hearing with the Secretary of the Commission within 30 days of the Certificate of Service (mailing) below (as stipulated in APC&EC Regulation No. 8.214. If you want to appeal this matter, your appeal must be filed in accordance with Arkansas Pollution Control & Ecology Commission's (APC&EC or Commission) Regulation No. 8, available at <https://www.adeq.state.ar.us>. If you have any questions regarding the appeal procedure, please contact your attorney. All appeal procedures must be filed with the Commission's Secretary who is located at 101 E. Capitol, Suite 205, Little Rock, AR 72201. For directions to the Commission's office, call (501) 682-7893.

I, Karen Blue, hereby certify that a copy of this Notice of Decision & Permit Sign-off Sheet has been mailed to Kathy Shoemaker, on this 27th day of June, 2018.

Karen Blue

Signature of person mailing this notice

Date of Service: 6-27-18

(Certificate of Mailing of Notice of Decision)

Effective Date: 6-27-18

END OF PERMIT SIGN-OFF SHEET



UNITED STATES ENVIRONMENTAL PROTECTION AGENCY
REGION 5
77 WEST JACKSON BOULEVARD
CHICAGO, IL 60604-3590

JUN 23 2014

Mr. John Hannah
Environmental, Health & Safety Manager
Veolia ES Technical Solutions, L.L.C.
4301 Infirmaroy Road
West Carrollton, Ohio 45449

REPLY TO THE ATTENTION OF:

Re: Final Federal RCRA Permit, Veolia ES Technical Solutions, L.L.C.
West Carrollton, Ohio, OHD 093 945 293

Dear Mr. Hannah:

Enclosed is a copy of the Federal portion of a Resource Conservation and Recovery Act (RCRA) Hazardous Waste permit for the above-referenced facility. The complete RCRA Hazardous Waste permit contains both Federal permit conditions (contained herein) and State permit conditions, which were issued separately by the State of Ohio RCRA program authorized under Title 40 of the Code of Federal Regulations (40 CFR) Part 271. Any hazardous waste activity not included in the Federal portion of the RCRA permit or in the State portion of the RCRA permit is prohibited when such activity requires a RCRA Hazardous Waste permit.

The draft Federal RCRA permit was publicly noticed in the "Dayton Daily News" and radio station "WHIO" on or about July 23, 2013. A copy of the draft Federal RCRA permit was available for review at the Dayton Metro – West Carrollton Branch, 300 East Central Avenue, West Carrollton, Ohio 45449. The public comment period extended from July 23 to September 6, 2013. A public hearing was conducted on August 22, 2013, 6:30 p.m. at the West Carrollton Municipal Building Community Room, 300 East Central Avenue, West Carrollton, Ohio 45449.

The comment received by U.S. Environmental Protection Agency on the draft Federal RCRA permit during the public comment period was submitted by Veolia ES Technical Solutions, L.L.C. No comments from any concerned citizens were received. EPA's Response Summary to comments is enclosed with this letter.

You may appeal the issuance of this permit by filing a petition for review with the Environmental Appeals Board.

A petition for review of any condition of a RCRA permit decision must be filed with the Environmental Appeals Board within 30 days after EPA serves notice of the issuance of the final permit decision. 40 CFR § 124.19(a)(3). When EPA serves the notice by mail, service is deemed to be completed when the notice is placed in the mail, not when it is received. However, to compensate for the delay caused by mailing, the 30-day deadline for filing a petition is extended

by three days if the final permit decision being appealed was served on the petitioner by mail. 40 CFR § 124.20(d). Petitions are deemed filed when they are received by the Clerk of the Board at the address specified for the appropriate method of delivery. 40 CFR § 124.19(a)(3) and 40 CFR § 124.19(i). Additional information regarding petitions for review may be found in the Environmental Appeals Board Practice Manual (January 2013) and A Citizen's Guide to EPA's Environmental Appeals Board, both of which are available at http://yosemite.epa.gov/oa/EAB_Web_Docket.nsf/General+Information/Environmental+Appeals+Board+Guidance+Documents?OpenDocument.

Eligibility to appeal the Federal permit is discussed further in 40 CFR §124.19. General filing requirements are contained in the Practice Manual, The Environmental Appeals Board and A Citizens' Guide to EPA's Environmental Appeals Board.

All documents that are sent through the U.S. Postal Service (except by Express Mail) must be addressed as follows:

Clerk of the Board
U.S. Environmental Protection Agency
Environmental Appeals Board
1200 Pennsylvania Avenue, NW
Mail Code 1103M
Washington, DC 20460-0001

Documents that are hand-carried in person, delivered via courier, mailed by Express Mail, or delivered by a non-U.S. Postal Service carrier (e.g., Federal Express or UPS) must be delivered to:

Clerk of the Board
U.S. Environmental Protection Agency
Environmental Appeals Board
1201 Constitution Avenue, NW
U.S. EPA East Building, Room 3334
Washington, DC 20004

A copy of the petition should also be sent to:

RCRA Branch (LR-8J)
U.S. Environmental Protection Agency, Region 5
77 West Jackson Boulevard
Chicago, Illinois 60604-3590

The procedures for filing an appeal are found in 40 CFR § 124.19. The administrative appeal procedures must be completed prior to any action seeking judicial review.

This Federal permit is effective July 27, 2014 and valid until December 31, 2023, unless the Federal permit is revoked and reissued, or terminated pursuant to 40 CFR § 270.41 and § 270.43. Failure to comply with any conditions of the Federal permit may result in civil and/or criminal penalties.

If you have any questions concerning this permit, please contact Mr. Jae Lee of my staff, at (312) 886-3781.

Sincerely,

A handwritten signature in black ink, appearing to read 'M. Guerriero', written in a cursive style.

Margaret M. Guerriero
Director
Land and Chemicals Division

Enclosure

cc: Jeremy Carroll, OEPA

FINAL

**UNITED STATES ENVIRONMENTAL PROTECTION AGENCY
REGION 5**

RESOURCE CONSERVATION AND RECOVERY ACT PERMIT

Facility Name and Location: **Veolia ES Technical Solutions, L.L.C.**
4301 Infirmiry Road
West Carrollton, Ohio 45449

Owner: **Veolia ES Technical Solutions, L.L.C.**
700 East Butterfield Road, Suite 201
Lombard, Illinois 60148

Operator: **Veolia ES Technical Solutions, L.L.C.**
700 East Butterfield Road, Suite 201
Lombard, Illinois 60148

U.S. EPA Identification Number: **OHD 093 945 293**

Effective Date: **July 27, 2014**

Expiration Date: **December 31, 2023**

Authorized Activities:

The United States Environmental Protection Agency hereby issues a Resource Conservation and Recovery Act permit (hereinafter referred to as “this permit”) to Veolia ES Technical Solutions, L.L.C. (Owner and Operator hereinafter referred to as the “Permittee” or addressed in the second person as “you”) in connection with the hazardous waste management operations at Veolia ES Technical Solutions, L.L.C., in West Carrollton, Ohio (the “facility”).

This permit is issued under the Solid Waste Disposal Act, as amended by the Resource Conservation and Recovery Act of 1976, and the Hazardous and Solid Waste Amendments (HSWA) of 1984 (42 USC § 6901 *et seq.*) (collectively referred to as “RCRA”) and EPA’s regulations promulgated thereunder (codified, and to be codified, in Title 40 of the Code of Federal Regulations (40 CFR)).

Specifically, this permit addresses: air emission standards for process vents (40 CFR Part 264, Subpart AA); equipment leaks (40 CFR Part 264 Subpart BB); and tanks, containers, and miscellaneous units (40 CFR Part 264 Subpart CC).

This permit contains the applicable federal RCRA permit conditions for the facility. The Permittee also has a state RCRA permit which contains conditions issued by the State of Ohio's RCRA program authorized under 40 CFR Part 271. Any hazardous waste activity which requires a RCRA permit and is not included in either this permit or the state RCRA permit is prohibited.

Permit Approval:

On June 28, 1989, the state of Ohio received final authorization according to Section 3006 of RCRA, 42 USC § 6926, and 40 CFR Part 271, to administer the pre-HSWA RCRA hazardous waste program. The state of Ohio also received final authorization to administer certain additional RCRA requirements on several occasions since then.

However, because EPA has not yet authorized the state of Ohio to administer certain regulations, including the air emission standards for process vents, equipment leaks and containers, EPA is issuing the RCRA permit requirements for operations at the Permittee's facility which fall under these regulations.

You must comply with all terms and conditions contained in this permit. This permit consists of all conditions contained herein; the documents attached hereto; all documents cross-referenced in these documents; approved submittals (including plans, schedules and other documents); applicable regulations in 40 CFR Parts 124, 260, 261, 262, 264, 268 and 270; and applicable provisions of RCRA.

This permit is based on the assumption that the information submitted: (1) in the Permittee's RCRA Part B Permit Application dated May 3, 2013, and all other modifications to that application (hereinafter referred to as the "Part B Permit Application") is accurate; and (2) that the facility is configured, operated and maintained as specified in the permit and as described in the Part B Permit Application and other relevant documents.

Any inaccuracies in the submitted information may be grounds for EPA to terminate, revoke and reissue, or modify this permit in accordance with 40 CFR §§ 270.41, 270.42 and 270.43; and for enforcement action. You must inform EPA of any deviation from, or changes in, the information in the Part B Permit Application and other pertinent documents that might affect your ability to comply with the applicable regulations or conditions of this permit.

Opportunity to Appeal:

Petitions for review must be submitted within 30 days after EPA serves notice of the final permit decision. Any person who filed comments on the draft permit or participated in the public hearing may petition the Environmental Appeals Board to review any condition of the permit decision. Any person who failed to file comments or failed to participate in the public hearing on the draft permit may file a petition for review only to the extent of the changes from the draft to the final permit decision. The procedures for permit appeals are found in 40 CFR § 124.19.

Effective Date:

This permit is effective as of July 27, 2014 and will remain in effect until December 31, 2023 unless revoked and reissued under 40 CFR § 270.41, terminated under 40 CFR § 270.43, or continued in accordance with 40 CFR § 270.51(a).

By:

Margaret M. Guerriero, Director
Land and Chemicals Division

Date:

6/20/2014

Administrative Record Index *(Final RCRA Permit)*

Veolia ES Technical Solutions, L.L.C.
West Carrollton, Ohio
OHD 093 945 293

<u>Title</u>	<u>Date</u>	<u>Prepared by</u>
1. Part A Application	May 3, 2013	Veolia
2. Part B Permit Application	May 3, 2013	Veolia
3. EJ Information	May 2013	EPA
4. Subparts AA/BB/CC Information (Section L of Part B Application)	June 12, 2013	Veolia
5. Site Visit Observation Notes	June 27, 2013	EPA
6. Revised Section A, B, and D of Part B Application	July 18, 2013	Veolia
7. Subparts AA/BB/CC Information (Updated Section L of Part B Application)	July 19, 2013	Veolia
8. Fact Sheet	July 22, 2013	OEPA/EPA
9. Draft RCRA Permit (EPA)	July 22, 2013	EPA
10. Comments on Draft Permit	September 5, 2013	Veolia
11. RCRA Final Permit (State)	December 31, 2013	OEPA
12. Part B Application Addendum	March 17, 2014	Veolia
13. Revised Draft Federal Permit Comments	March 17, 2014	Veolia
14. Response Summary	June 2014	EPA
15. Final RCRA Permit	June 2014	EPA

EPA: United States Environmental Protection Agency

OEPA: Ohio Environmental Protection Agency

RCRA: Resource Conservation Recovery Act

EJ: Environmental Justice

Subpart AA: Air Emission Standards for Process Vents

Subpart BB: Air Emission Standards for Equipment Leaks

Subpart CC: Air Emission Standards for Tanks and Containers

July 2013

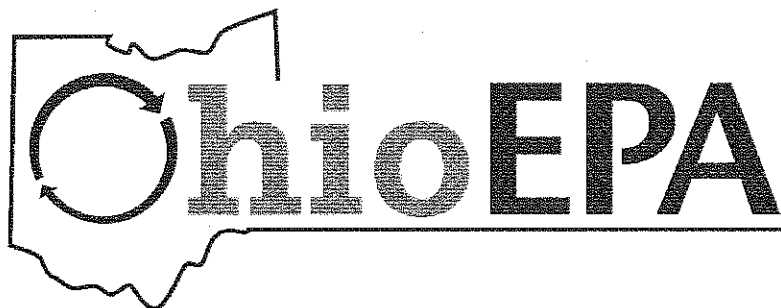

Draft Hazardous

Waste Permit Renewal

Facility Name: Veolia ES Technical Solutions, L.L.C.

U.S. EPA I.D.: OHD093945293

Location:

4301 Infirmery Road
West Carrollton, OH 45449

Facility Owner:

Veolia ES Technical Solutions, L.L.C.
700 East Butterfield Road, Suite 201
Lombard, IL 60148

Facility Operator:

Veolia ES Technical Solutions, L.L.C.
P.O. Box 453
West Carrollton, OH 45449

Activity:

Permit renewal for storage and treatment of
hazardous waste.

Comment Period:

[Beginning Date - Ending Date]

Submit Comments to:

Ohio EPA
Shawn Sellers
Division of Materials and Waste Management

P.O. Box 1049
Columbus, Ohio 43216-1049
(614) 644-2621
shawn.sellers@epa.ohio.gov

U.S. EPA, Region 5
Jae Lee
RCRA Branch (LR-8J)
77 West Jackson Boulevard
Chicago, Illinois 60604-3590
1-800-621-8431 ext. 63781
lee.jae@epa.gov

What is the history of the hazardous waste program?

The Resource Conservation and Recovery Act (RCRA), an amendment to the Solid Waste Disposal Act, was passed in 1976. The main reason for the amendment was to address the growing volume of municipal and industrial solid waste generated across the United States. A few goals established by RCRA include the protection of human health and the environment from potential hazards of waste disposal, to reduce the amount of waste generated and to ensure that waste produced are managed in an environmentally sound manner.

When RCRA was written, U.S. Congress' intent for the states was to assume primary responsibility for implementing the hazardous waste regulations with oversight from the United States Environmental Protection Agency (U.S. EPA). U.S. EPA must approve each state as an authorized state. To become an authorized state, each must demonstrate that the state programs are at least equivalent to and consistent with federal laws, provides adequate enforcement authority and provides availability of information similar to the federal program. Since 1989, the State of Ohio has been an authorized state by U.S. EPA for the majority of the hazardous waste program.

Currently, the State of Ohio is not authorized by U.S. EPA to issue a permit for organic air emissions (40 CFR Part 264, Subparts BB and CC) from hazardous waste storage units. U.S. EPA has drafted a RCRA permit to address organic air emissions from hazardous waste storage units. U.S. EPA's draft permit and the State of Ohio's draft permit have been issued concurrently and both share the same comment period.

How can I become more involved?

Public meeting has been pre-scheduled.

A public meeting will be held to receive comments on August 22, 2013 at 6:30 p.m. at the West Carrollton Municipal Building Community Room, 300 E. Central Ave., West Carrollton, OH. Oral comments will be received during the public meeting. All persons, including the applicant, may submit written comments relating to this draft action. Written comments may be submitted before the end of the comment period to the address in the box on the left.

The comment period begins on [date begins], and ends on [date ends]. A copy of the permit application and the draft permit is available for review by the public at the following locations:

Ohio EPA, Southwest District Office
401 East Fifth Street
Dayton, Ohio 45402
(937) 285-6357

Ohio EPA, Central Office
Division of Materials and Waste Management
Lazarus Government Center
50 West Town St., Suite 700
Columbus, Ohio 43215
(614) 644-2621

A copy of the draft permit is available for review by the public online at the following locations:

The Ohio draft permit is available for review by the public online under the "Stakeholder Input" tab at:
epa.ohio.gov/dmwm/.

Dayton Metro Library
West Carrollton Branch
300 E. Central Ave.
West Carrollton, OH 45449

The federal draft permit is available for review by the public at:
epa.gov/region5/waste/permits/actions.htm.

Within sixty (60) days of the close of the public comment period, Ohio EPA will, without prior hearing, issue the permit (or deny the request) in accordance with Chapter 3734 of the Ohio Revised Code (ORC). If Ohio EPA approves the application, taking into account public comments, a renewal permit will be issued with terms and conditions as are necessary to ensure compliance with hazardous waste rules.

What does the facility do?

Veolia ES Technical Solutions, L.L.C. is a permitted hazardous waste storage and treatment facility located in West Carrollton, Ohio. No hazardous waste disposal takes place on site. All waste that comes into the facility is either treated or repackaged and sent off-site to a final disposal or recycling destination.

What would this hazardous waste permit allow the facility to do?

This permit allows Veolia ES Technical Solutions, L.L.C. to store up to 158,400 gallons of containerized hazardous waste in two container storage areas – the Drum Storage Building and the Decant Building.

Additionally, the facility is authorized to store and treat a total volume of 462,000 gallons of hazardous waste in 40 tanks. Treatment activities allowed would be decanting, distillation and fuel blending. Tanks are located in four areas at the facility: the East Tank Farm, the West Tank Farm, the Solvent Distillation Process Area and the Decant Building.

What is the regulatory basis to support this permit renewal?

The Director has determined that Veolia ES Technical Solutions, L.L.C. has submitted an application for renewal one hundred eighty (180) days prior to the expiration date of its present permit which was issued by Ohio EPA on September 30, 2013. The Director has considered the application, inspection reports, a report regarding the facility's compliance with the present permit, and the rules adopted under ORC Section 3734. The Director has found that the Part B permit application meets the Director's performance standards and that the facility has a history of compliance with this chapter, rules adopted under it, the existing permit, and

orders entered into, which demonstrates reliability, expertise, and competency to subsequently operate the facility under this chapter, the rules, and the permit.

Who can I contact for more information?

For additional information, please contact Thomas Koch at (937) 285-6594 or Jae Lee of the U.S. EPA Regional Office in Chicago, Illinois at (312) 886-3781.



UNITED STATES ENVIRONMENTAL PROTECTION AGENCY
REGION 5
77 WEST JACKSON BOULEVARD
CHICAGO, IL 60604-3590

JUN 23 2014

Reference Desk Librarian
West Carrollton-Dayton Metro Library
300 East Central Avenue
West Carrollton, Ohio 45449

REPLY TO THE ATTENTION OF:

Re: Final Federal RCRA, Veolia ES Technical Solutions, L.L.C.
West Carrollton, Ohio, OHD 093 945 293

Dear Madam or Sir:

The U.S. Environmental Protection Agency intends to issue a final Hazardous Waste Management permit to Veolia ES Technical Solutions, L.L.C., West Carrollton, Ohio.

The draft federal RCRA permit was publicly noticed in the Dayton Daily News and radio station WHIO (am) on July 25, 2013. A copy of the draft federal RCRA permit was available for review at the West Carrollton-Dayton Metro Library, 300 East Central Avenue, West Carrollton, Ohio 45449. The public comment period extended from July 25 to September 6, 2013. A public hearing was conducted on August 22, 2013, 6:30 p.m. at the West Carrollton Municipal Building Community Room, 300 East Central Avenue, West Carrollton, Ohio 45449.

Please make available for public examination this letter and the enclosed documents for at least seventy-five (75) days under "Reference Materials – Veolia ES Technical Solutions, L.L.C.". The following items are enclosed.

- Final Permit
- Responsive Summary

Thank you for your assistance. If you have any questions, please call me at 312-886-3781.

Sincerely,

A handwritten signature in blue ink, appearing to read "Jae B. Lee".

Jae B. Lee, Permit Writer
RCRA Branch
Land and Chemicals Division



UNITED STATES ENVIRONMENTAL PROTECTION AGENCY
REGION 5
77 WEST JACKSON BOULEVARD
CHICAGO, IL 60604-3590

JUN 23 2014

REPLY TO THE ATTENTION OF:

Mr. Jeremy Carroll
Ohio Environmental Protection Agency
Division of Hazardous Waste Management
Post Office Box 1049
Columbus, Ohio 43266-0149

Re: Final Federal RCRA Permit, Veolia ES Technical Solutions, L.L.C.
West Carrollton, Ohio, OHD 093 945 293

Dear Mr. Carroll:

Enclosed please find a copy of the final Federal Resource Conservation and Recovery Act permit and cover letter to the above-referenced facility.

If you have any questions, please contact Jae Lee of my staff at (312) 886-3781.

Sincerely,

A handwritten signature in blue ink that reads "for Mary S. Setnicar".

Mary S. Setnicar, Chief
RCRA/TSCA Programs Section
Land and Chemicals Division

Enclosure

Enforcement Action Summary Report

Facility *Aragonite*

<i>Date Received</i>	<i>Agency</i>	<i>Enforcement Type</i>	<i>Alleged Violation</i>	<i>Proposed Penalty</i>	<i>Status</i>	<i>Resolution Date</i>	<i>Penalty Paid</i>
10/20/2016	UDEQ	Notice of Violation	1) Storage facility for water supply had a leak at the time of inspection, 2) the public water supply storage vessel showed signs of a leak.	\$0.00	Resolved w/o Penalty	12/14/2016	\$0.00
		<i>EA Number:</i>	<i>Description of Resolution:</i>	Repaired the tanks.			
2/8/2017	UDEQ - DDW	Notice of Violation	Failure to monitor and report for pesticides and volatile organic compounds in 2016.	\$0.00	Resolved w/o Penalty	2/15/2017	\$0.00
		<i>EA Number:</i>	<i>Description of Resolution:</i>	Updated testing was conducted.			
5/16/2018	UDEQ - Division of Air Quality	Notice of Violation	Failure to submit stack test results, deviation reports, leak detection and repair reports, Benzene NESHAP reports, semi-annual reports and compliance certifications in a timely manner.	\$23,750.00	Resolved	5/21/2018	\$23,750.00
		<i>EA Number:</i>	<i>Description of Resolution:</i>				

1/28/2019	US DEA	Notice of Violation	1) Failure to file annual inventory, 2) delinquent filing of quarterly ARCOS reports, failure to maintain a separate file for Schedule 1 and 2 and Schedule 3 through five controlled substances, 4) failure to record time of annual inventory.	\$120,000.00	Resolved	5/8/2019	\$96,000.00
-----------	--------	---------------------	--	--------------	----------	----------	-------------

EA Number:

Description of Resolution:

Payment of a civil penalty.

9/26/2019	Utah Department of Commerce	Penalty Notice	Failure to report to the division any adverse action taken by another licensing jurisdiction.	\$300.00	Resolved	10/10/2019	\$300.00
-----------	-----------------------------	----------------	---	----------	----------	------------	----------

EA Number:

Description of Resolution:

Paid civil penalty

1/23/2020	UDEQ	Compliance Advisory	The facility's Public Water System rating is expected to be downgraded for the following deficiencies: 1) area within 50 feet of a storage tank not graded to prevent standing water, 2) lack of an approved DWSP plan at two locations.	\$0.00	Pending		\$0.00
-----------	------	---------------------	--	--------	---------	--	--------

EA Number:

Description of Resolution:

4/8/2020	UDEQ	Notice of Violation	29 alleged violations resulting from the annual inspection conducted in the Fall 2019.	\$106,840.00	Pending		\$0.00
----------	------	---------------------	--	--------------	---------	--	--------

EA Number:

2001004

Description of Resolution:

7/15/2020	Alabama Board of Pharmacy	Consent Administrative Order	1) Conducting operations in the State but failing to timely renew a permit, 2) Failure to conduct business in accordance with the State rules because of violations settled with the US DEA in January 2019.	\$10,000.00	Resolved	8/10/2020	\$10,000.00
-----------	---------------------------	------------------------------	--	-------------	----------	-----------	-------------

EA Number: 19-L-0162 *Description of Resolution:* Paid a civil penalty.

8/31/2020	US EPA	Warning Letter/Notice	Incineration of materials in violation of the prohibition on dilution of certain hazardous wastes by incineration.	\$0.00	Pending		\$0.00
-----------	--------	-----------------------	--	--------	---------	--	--------

EA Number: *Description of Resolution:*

12/9/2020	Alabama Board of Pharmacy	Compliant	1) Failure to disclose an enforcement action in another jurisdiction on a permit application and applicable Alabama Board of Pharmacy rules violations from lack of disclosure.	\$2,000.00	Resolved	2/24/2021	\$2,000.00
-----------	---------------------------	-----------	---	------------	----------	-----------	------------

EA Number: 20-L-0097 *Description of Resolution:* Paid an administrative penalty.

12/15/2020	Arizona Board of Pharmacy	Penalty Notice	Failure to notify the Board of a prior enforcement action in another jurisdiction.	\$250.00	Resolved	1/26/2021	\$250.00
------------	---------------------------	----------------	--	----------	----------	-----------	----------

EA Number: *Description of Resolution:* Entered into a consent order.

1/15/2021	US EPA	Warning Letter/Notice	1) Failure to monitor emissions from the Corrosives Unit, Blended Waste Feed, Aqueous Waste Feed, and Sludge Waste Feed operation, 2) 24 open ended valves on the carbon system, 3) a rupture disk operating above the no detectable emissions standard, 4) Failure to record the date of first repair attempt, 5) Excess emissions from 12 pressure relief devices and 5 connectors, 6) Failing to record information on equipment tagged for repair, 7) Storing light liquid material in containers that had leaks, 8) Failure to adequately train employees to conduct Method 21 monitoring, 9) Failure to use equipment that adequately monitors for Method 21, 10) Failure to repair 3 pieces of equipment in 15 days.	\$470,000.00	Pending	\$0.00
-----------	--------	-----------------------	---	--------------	---------	--------

EA Number:

Description of Resolution:

2/26/2021	Bureau of Alcohol, Tobacco and Fire Arms	Warning Letter/Notice	Failure to timely/accurately enter all required explosive inventory identification and quantity information in a daily summary of magazine transaction (per magazine)	\$0.00	Resolved w/o Penalty	2/26/2021	\$0.00
-----------	--	-----------------------	---	--------	----------------------	-----------	--------

EA Number:

Description of Resolution:

Provided corrective actions to the Agency.

3/26/2021	UDEQ	Notice of Violation	12 alleged violations related to permit conditions on waste storage conditions, timing, training and rejection procedures identified during the 2020 annual inspection.	\$0.00	Pending	\$0.00
-----------	------	---------------------	---	--------	---------	--------

EA Number: NOV 2102003

Description of Resolution:

Enforcement Action Summary Report

Facility *El Dorado*

<i>Date Recieved</i>	<i>Agency</i>	<i>Enforcement Type</i>	<i>Alleged Violation</i>	<i>Proposed Penalty</i>	<i>Status</i>	<i>Resolution Date</i>	<i>Penalty Paid</i>
3/14/2019	ADEQ	Notice of Violation	1) Allowing water to remain in secondary containment longer than 24 hours, thus impeding the ability to monitor for leaks, 2) failure to properly document inspections for secondary containment.	\$8,000.00	Resolved	5/17/2019	\$8,000.00
			<i>EA Number:</i> LIS 19-048	<i>Description of Resolution:</i>	Entered into the administrative consent order.		
11/21/2019	ADEQ	Notice of Violation	1) Opacity issues at kiln 1, 2) Opacity issues at kiln 2 and 3) Open diverts at kiln 2 require additional explanation to the air regulators.	\$10,020.00	Resolved		\$6,513.00
			<i>EA Number:</i> LIS 21-120	<i>Description of Resolution:</i>	Paid a civil penalty and provided ergonomic hose reloading equipment to the El Dorado fire department.		
12/9/2019	Delaware Dept. of Natural Resources	Notice of Violation	Failure to provide the Department of Natural Resources with facility copies of infectious waste manifests received from Delaware generators.	\$0.00	Resolved w/o Penalty	1/8/2020	\$0.00
			<i>EA Number:</i> 19-SW-43	<i>Description of Resolution:</i>	Supplied the required manifests.		

8/25/2020	ADEQ	Warning Letter/Notice	Discharge exceedance of the effluent limitation for Mercury at the 007 outfall during the 2nd Quarter of 2020.	\$0.00	Pending		\$0.00
-----------	------	-----------------------	--	--------	---------	--	--------

EA Number:

Description of Resolution:

8/31/2020	US EPA	Warning Letter/Notice	Incineration of materials in violation of the prohibition on dilution of certain hazardous wastes by incineration.	\$0.00	Pending		\$0.00
-----------	--------	-----------------------	--	--------	---------	--	--------

EA Number:

Description of Resolution:

10/22/2020	ADEQ	Warning Letter/Notice	Mercury stormwater exceedance.	\$0.00	Pending		\$0.00
------------	------	-----------------------	--------------------------------	--------	---------	--	--------

EA Number:

Description of Resolution:

2/11/2021	FRA	Notice of Non-Compliance	A rail car not sealed appropriately because the bolts on the manway were not tool tight.	\$5,000.00	Resolved	3/11/2021	\$4,000.00
-----------	-----	--------------------------	--	------------	----------	-----------	------------

EA Number:

FRA No. ZCED 2020-1(HMT)

Description of Resolution:

Paid civil penalty.

2/19/2021	FRA	Notice of Non-Compliance	Bolts on a rail car manway were not tool tight.	\$2,000.00	Resolved	3/11/2021	\$1,500.00
-----------	-----	--------------------------	---	------------	----------	-----------	------------

EA Number:

FRA No. ZCED 2020-2(HMT)

Description of Resolution:

Paid civil penalty.

3/30/2021	ADEQ	Notice of Violation	1) Storage of rejected explosives while waiting to obtain transportation permits to remove them from the site.	\$0.00	Dismissed	5/25/2021	\$0.00
-----------	------	---------------------	--	--------	-----------	-----------	--------

EA Number:

Description of Resolution:

Arkansas DEQ withdrew the alleged violation due to extenuating circumstances.

**VEOLIA ES TECHNICAL SOLUTIONS, L.L.C.
PORT ARTHUR, TX**

Inspection Date	Type of inspection	Name of inspector and Regulatory Agency	Alleged Violations	VEOLIA Responses and/or Corrective Actions Taken
2/15/2017	ATF		No Violations	
3/9/2017	CAA	TCEQ	<p>Alleged Violations:</p> <p>1.) Failure to maintain the Carbon Monoxide incinerator.</p> <p>2.) Failure to maintain Carbon Monoxide emissions of 100 parts per million by volume (ppmv) at the incinerator.</p> <p>3.) Failure to maintain incinerator minimum combustion temperatures.</p> <p>4.) Failure to maintain Arsenic and Chormium emission rates at the Incinerator.</p> <p>5.) Failure to maintain combined Cadmium-Lead and combined Arsenic-Beryllium-Chromium emissions at the Incinerator.</p> <p>6.) Failure to maintain the Carbon Monoxide emission rate of 17.10 pounds per hour during start-up at the Incinerator.</p>	<p>4/18/2017 Received NOV</p> <p>5/27/2017 Submitted Corrective Action Plan</p> <p>9/29/2017 Received a letter from the TCEQ stating adequate compliance documentation was received and no further action required</p>
6/15/2017	TPDES	TCEQ	No Violations - Three Areas of Concern	8/9/2017 Received a letter from the TCEQ stating no violations are alleged.
2/22/2018	OPCC	TCEQ	<p>Alleged Violations</p> <p>1.) Failure to maintain the CO emission rate at the Incinerator.</p> <p>2.) Failure to limit Carbon Monoxide concentration at 100 parts per million by volume (ppmv) at the</p> <p>3.) Failure to maintain Incinerator minimum combustion temperatures.</p> <p>4.) Failure to maintain Beryllium, Selenium, and Chromium emission rates at the Incinerator.</p>	<p>4/26/2018 Received Notice of Violation.</p> <p>5/25/2018 Submitted a Response to NOV.</p> <p>10/15/2018 Received a letter from TCEQ stating no further action required.</p>

**VEOLIA ES TECHNICAL SOLUTIONS, L.L.C.
PORT ARTHUR, TX**

Inspection Date	Type of inspection	Name of inspector and Regulatory Agency	Alleged Violations	VEOLIA Responses and/or Corrective Actions Taken
			5.) Failure to limit combined Arsenic-Beryllim-Chromium emissions at the Incinerator. 6.) Failure to maintain Mercury emission rates at the Incinerator. 7.) Failure to limit Mercury emissions at the Incineraotr. 8.) Failure to maintain the Hazardous Wsate Permit miminum voltage requirements at the Ionizing Wet Scrubber. 9.) Failure to maintain EPA and Hazardous Waste Permit minimum voltage requirments at the Ionizing Wet Scrubber (IWS) equipment.	
6/13-21/2018	RCRA	TCEQ	Alleged Violations 1.) Failure to maintain inspection records as required by permit. 2.) Failure to Maintain aisle space to allow unobstructed movement of personnel and emergency response equipment. Additional Issues 3.) A concern the regulated entity may not be meeting the requirements of properly maintaining an accuarate storage inventory amount. 4.) The concern is the regulated entity may not be meeting the requirements of properly storing incompatible waste.	9/21/2018 Submitted a response to TCEQ. 1/4/2019 Received Letter from TCEQ stating no further action required.

**VEOLIA ES TECHNICAL SOLUTIONS, L.L.C.
PORT ARTHUR, TX**

Inspection Date	Type of inspection	Name of inspector and Regulatory Agency	Alleged Violations	VEOLIA Responses and/or Corrective Actions Taken
7/18/2018	Transportation Ten Day Yard	TCEQ	No Issues Found	
			1.) Paperwork Error on the Chain of Custody	10/19/2018 Posted required public notice in all Veolia Port Arthur Buildings 10/22/2018 Submitted copy of Monitoring Violation Public Notice and Certificate of Delivery to TCEQ. No further action required.
1/17/2019	CAA	TCEQ	<p>Alleged Violations</p> <p>1.) Failure to maintain tons per year emissions for permitted sources on a 12 month rolling period basis.</p> <p>2.) Failure to maintain the Hazardous Waste Permit minimum voltage requirements at the Ionizing Wet Scrubber (IWS) equipment.</p> <p>3.) Failure to comply with the EPA and the Hazardous Waste Permit minimum voltage requirements at the Ionizing Wet Scrubber (IWS) equipment.</p> <p>4.) Failure to comply with the EPA minimum kilovolts-amps requirement at the Wet Electrostatic Precipitator (WESP).</p> <p>5.) Failure to maintain the CO emission rate at the Incinerator (EPN INCINSTK).</p> <p>6.) Failure to limit Carbon Monoxide concentration to 100 parts per million by volume (ppmv) at the Incinerator.</p> <p>7.) Failure to maintain Incinerator minimum combustion temperatures.</p>	<p>3/18/2019 Received NOV letter</p> <p>4/25/2019 Submitted Corrective Action Plan</p> <p>10/1/2019 Received letter from TCEQ stating no further action required.</p>

**VEOLIA ES TECHNICAL SOLUTIONS, L.L.C.
PORT ARTHUR, TX**

Inspection Date	Type of inspection	Name of inspector and Regulatory Agency	Alleged Violations	VEOLIA Responses and/or Corrective Actions Taken
			8.) Failure to certify the Permit Compliance Certification. 9.) Failure to report all instances of deviations.	
6/25/2019	LQG/UIC/Ten day facility	TCEQ	No Alleged Violations	8/1/2019 Received Letter from TCEQ stating no violations are being alleged.
12/16/2019	DEA	DEA	DEA controlled substances inventory was not conducted. No DEA controlled substances were present at the Veolia site at the time.	1/17/2020 Veolia submitted a formal biennial inventory of controlled substances to the DEA. The inventory was zero(0).
1/22/2020	Foreign Soil Permit	USDEA	No Alleged Violations	
2/14/2020	TSD/LQG/Used Oil	TCEQ	Alleged Violations 1.) Failure to follow the Waste Analysis Plan 2.) Failure to separator protect storage containers holding hazardous waste that is incompatible with any waste or other material stored nearby in other containers. 3.) Failure to provide the hazardous waste accumulation (>1 year) was solely for the purpose of holding of such quantities of hazardous waste as are necessary to facilitate proper disposal. 4.) Failure to post the "TCEQ Permit Unit No. _" sign at the permitted facility unit. 5.) Failure to maintain disposal records for the disposal of waste oil. 6.) Failure to maintain adequate (e.g., include inspector's full name and time of inspection) monthly safety inspection records (e.g., fire extinguishers, first aid	6/12/2020 Received NOV Letter 7/15/2020 Submitted Corrective Action Plan to TCEQ. 10/26/2020 Received No Further Action Letter

**VEOLIA ES TECHNICAL SOLUTIONS, L.L.C.
PORT ARTHUR, TX**

Inspection Date	Type of inspection	Name of inspector and Regulatory Agency	Alleged Violations	VEOLIA Responses and/or Corrective Actions Taken
			<p>kits, Self-Contained Breathing Apparatus (SCBA), showers, and Table III.E.3. - Emergency Equipment of the Contingency Plan) for a period of 3 years. records of the Protective Gear Designated for Emergency Use.</p> <p>8.) Failure to maintain the date and nature of any repairs or other remedial actions documented on the weekly Container Storage Areas inspections.</p> <p>9.) Failure to follow a written schedule for inspecting security devices.</p>	
2/14/2020	UIC	TCEQ	No Alleged Violations	
2/14/2020	Transfer Facility Compliance	TCEQ	No Alleged Violations	3/2/2020 Received letter from the TCEQ stating no alleged violations.
2/26/2020	Public Drinking Water	TCEQ	<p>Alleged Violation</p> <p>1.) Failure to perform maintenance and housekeeping practices used by a PWS to ensure the good working condition and general appearance of the systems' facilities and equipment.</p> <p>Area of Concern</p> <p>1.) Failure to have a complete and up-to-date monitoring plan.</p>	<p>6/29/2020 Received NOV letter from TCEQ.</p> <p>7/22/2020 Submitted Corrective Action Plan to TCEQ.</p> <p>11/24/2020 Received letter from TCEQ stating no further action required.</p>
3/2/2020	OPCC	TCEQ	<p>Alleged Violations</p> <p>1. -3.) Failure to comply with the EPA and the Hazardous Waste Permit minimum voltage requirements at the Ionizing Wet Scrubber (IWS)</p>	<p>6/9/2020 Received NOV letter</p> <p>7/8/2020 Submitted Corrective Actin Plan to TCEQ.</p> <p>10/20/2020 Received letter from TCEQ stating no further action required.</p>

**VEOLIA ES TECHNICAL SOLUTIONS, L.L.C.
PORT ARTHUR, TX**

Inspection Date	Type of inspection	Name of inspector and Regulatory Agency	Alleged Violations	VEOLIA Responses and/or Corrective Actions Taken
			<p>equipment.</p> <p>4.) Failure to maintain the CO emission rate of 17.10 pounds per hour at the Incinerator (EPN INCINSTK).</p> <p>to 100 parts per million by volume (ppmv) at the Incinerator.</p> <p>6. - 7.) Failure to maintain Incinerator minimum combustion temperatures.</p> <p>8.) Failure to comply with the EPA minimum kilovolts-amps requirement at the Wet Electrostatic Precipitator (WESP).</p> <p>9.) Failure to conduct leak detection and repair monitoring.</p>	
8/4/2020	Wastewater	TCEQ	<p>Alleged Violations</p> <p>1.) Failure to report any effluent violation that deviates from the permitted effluent limitation by more than 40% to the Regional office and the Enforcement Division within five working days of becoming aware of the noncompliance. The noncompliance occurred in September 2019.</p>	<p>8/7/2020 Submitted noncompliance notifications to the TCEQ.</p> <p>9/30/2020 Received letter from TCEQ stating no further action required.</p>
12/11/2020	RCRA	TCEQ	No Violations	
1/6-8/2021	ATF		No Violations	
1/11/2021	OPCC	TCEQ	<p><u>Alleged Violations - NOV</u></p> <p>1.) Failure to maintain an emission rate below the</p>	<p>1/27/2021 Received Notice of Violation</p> <p>1/27/2021 Received Notice of Enforcement</p>

**VEOLIA ES TECHNICAL SOLUTIONS, L.L.C.
PORT ARTHUR, TX**

Inspection Date	Type of inspection	Name of inspector and Regulatory Agency	Alleged Violations	VEOLIA Responses and/or Corrective Actions Taken
			<p>allowable Carbon Monoxide (CO) emission limits of 17.1 pounds per hour (lbs/hr) from Emission Point Number (EPN) INCINSTK.</p> <p>2.) Failure to maintain the CO gas concentration below 100 parts per million by volume (ppmv) at the EPN INCINSTK.</p> <p>3.) Failure to maintain the EPA and the Hazardous Waste Permit minimum voltae of 10 kilovolts at the Ionizing Wet Scrubber (IWS) equipment.</p> <p>4.) Failure to maintain the EPA minimum kilovolts-amps requirement of 15.8 kVA at the Wet Electrostatic Precipitator (WESP).</p> <p>5.) Failure to comply with the EPA and the Hazardous Waste Permit minimum voltage requirements at the Ionizing Wet Scrubber (IWS) equipment.</p> <p><u>Violations - NOE</u></p> <p>1.) Failure to maintain emissions below the allowable Caron monoxide (CO) emission limit of 17.1 lbs/hr from EPN INCINSTK.</p>	<p>2/3/2021 Submitted a request to reconsider Enforcement based on significant improvements over the past three years.</p> <p>4/16/2021 Received Proposed Agreed Order</p> <p>7/13/2021 Submitted a signed agreement order and penalty payment of \$3,420.</p>
11/9-10/2021	RCRA	TCEQ	<p>Alleged Violations</p> <p>1.) The investigator observed three Waste Determination records which have been marked incorrectly, in a manner which indicated the wastes would be hazardous and these wastes were Industrial Class 1 and Class 2. The waste determinations were corrected.</p>	

VEOLIA ES TECHNICAL SOLUTIONS, L.L.C.
PORT ARTHUR, TX

Inspection Date	Type of inspection	Name of inspector and Regulatory Agency	Alleged Violations	VEOLIA Responses and/or Corrective Actions Taken
			2.) Failure to place a Waste Stream Identification/ classification of the waste on Manifest 001968617VES	

Received Date	Incident Id	Media	Facility	Agency	Action	Incident Title	Monetary Fine	Description	Follow Up Action	Response Due Date	Status
1/28/2022	MAR-00674	Air	Marion	ODEQ	NOV	Notice of Civil Penalty Assessment and Order	15722	Exceeded non-emergency operating for the emergency fire pump and CO excess emission event.	Penalty paid.		Closed



Wendy Janney <wendy.janney@inmar.com>

[EXTERNAL] FW: 5 year Compliance history

Griffith, Leslie <LGriffith@covanta.com>
To: Wendy Janney <wendy.janney@inmar.com>

Fri, Jun 10, 2022 at 1:04 AM

Indianapolis and Manheim RDC 5 year compliance report.

Leslie Griffith

Director of Business Development



CES Healthcare Solutions

445 South Street

Morristown, NJ 07960

Tel: 862.222.5792

Email: LGriffith@covanta.com

<http://covantaenvironmental.com/>

Our mission is to ensure no waste is ever wasted.



From: Frotton, John <JFrotton@covanta.com>
Sent: Thursday, June 9, 2022 2:32 PM
To: Walsh, Pat <PWalsh@covanta.com>; Griffith, Leslie <LGriffith@covanta.com>
Subject: RDC 5 year Compliance history

There are no enforcement actions in the last 5 yrs at either HRDC , so there is no report for them

Respectfully,



John Frotton

Director of Material Profiling

Mobile: 973-722-3892

Our mission is to ensure no waste is ever wasted.

CONFIDENTIALITY AND PRIVACY NOTICE: Information transmitted in this email is proprietary to Covanta and is intended for use only by the individual or entity to which it is addressed. It may contain information that is private, privileged, confidential or exempt from disclosure under applicable law. If you are not the intended recipient or it appears that this mail has been forwarded to you without proper authority, you are notified that any use or dissemination of this information in any manner is strictly prohibited. In such cases, please inform the sender and delete this mail from your records.



Compliance History

September 2016 – April 2022

Agency	Inspection Date / Other	Summary of Results
Ohio EPA DERR, Hazardous Waste Management	November 19, 22-24, 2021	Semi-Annual Compliance Evaluation Inspection (CEI), in person and virtual site inspection.. The inspection resulted in two (2) violations that were abated at the time of the inspection: one 5-gallon satellite container was open; and there was inadequate aisle space at one storage location. There are no outstanding violations.
Ohio EPA DERR, Hazardous Waste Management	October 6, 2021	Ohio EPA approval of a Specific Trial Technology Request (“STTR”) for a scrubber water treatment technology.
Ohio EPA Division of Air Pollution Control	August 24, 2021	On August 24, 2021, the OEPA DAPC conducted an air inspection of the Facility. No violations were found.
Ohio EPA DERR, Hazardous Waste Management	July 9, 2021	Informal Compliance Inspection/Walk Through.
Ohio EPA DERR, Hazardous Waste Management	June 4, 2021	Groundwater Report Compliance Review. No violations were found.
Ohio EPA DERR, Hazardous Waste Management	April 29, 2021	RIS voluntarily disclosed an instance of noncompliance. RIS deviated from fingerprint sampling process in accordance with its Waste Analysis Plan (WAP). Upon discovery, RIS revised procedures and re-trained employees to address this violation.
Ohio EPA DERR, Hazardous Waste Management	November 18-20, 2020	Semi-Annual CEI, virtual site inspection.. No violations were found.
Ohio EPA DERR, Hazardous Waste Management	July 21 – July 23, 2020	Semi-Annual CEI, virtual site inspection. No violations were found.
Ohio EPA DERR, Hazardous Waste Management	July 13, 2020	Focused Compliance Inspection (FCI) of Post-Closure areas, virtual site inspection. No violations were found.
Ohio EPA DERR, Hazardous Waste Management	June 4, 2020	RIS submitted its Waste Minimization Report/Plan. No violations were found.
Ohio EPA Division of Air Pollution Control	May 22, 2020	RIS submitted a Relative Accuracy Test Audit (RATA) of its Continuous Emissions Monitoring (CEM) system.
Ohio EPA DERR, Hazardous Waste Management	April 24, 2020	RIS voluntarily disclosed an instance of noncompliance. RIS deviated from visual inspection and fingerprint sampling process in accordance with its Waste Analysis Plan (WAP). Upon discovery, RIS revised procedures and re-trained employees to address this violation.
Ohio EPA DERR, Hazardous Waste Management	March 30, 2020	Groundwater Report Compliance Review and Non-Financial Records Review. No violations were found.
Ohio EPA Division of Air Pollution Control	January 31, 2020	RIS voluntarily disclosed an instance of noncompliance in Title V Quarterly Report pertaining to discharge of combustion gases emitted to the atmosphere that contain carbon monoxide in excess of RIS hourly rolling average.
Ohio EPA Division of Environmental Response and Revitalization (“DERR”), Hazardous Waste Management	November 14, 2019	FCI. No violations were found.
Ohio EPA DERR, Hazardous Waste Management	October 23, 2019	RIS voluntarily disclosed an instance of noncompliance related to waste storage. RIS stored a container for longer than its permit limits. It was also noted that the container was not inspected at the expected permitted frequency. The container was treated upon its discovery. In addition, RIS did not follow visual inspection and fingerprint sampling in accordance with its WAP. Upon discovery, RIS revised procedures and re-trained employees to address this violation.
Ohio EPA DERR, Hazardous Waste Management	September 9, 10, and 11 2019	Semi-Annual CEI. Two (2) violations were noted related to container management. Violations were abated at the time of the inspection.
Ohio EPA DERR, Hazardous Waste Management	July 30, 2019	Groundwater Report Compliance Review. No violations were found.
Ohio EPA Division of Air Pollution Control	July 24, 2019	On July 24, 2019, the OEPA DAPC conducted an air inspection of the Facility. No violations were found.



Compliance History

September 2016 – April 2022

Agency	Inspection Date / Other	Summary of Results
Ohio EPA DERR, Hazardous Waste Management	June 18, 2019	FCI. Three (3) violations were noted related to container management. Violations were abated at the time of the inspection.
Ohio EPA Division of Air Pollution Control	May 8, 2019	RIS submitted the results of a Confirmatory Performance Test (CfPT) and Notice of Compliance with its Title V permit.
U.S. EPA, Division of Air Pollution Control	May 7, 2019	U.S. EPA conducted an inspection related to SubPart BB, CC permitted activities in tanks. In July 2020, RIS received correspondence from the May 2019 inspection. U.S. EPA proposed a Finding of Violation (“FOV”). Discussions are continuing between RIS and U.S. EPA.
Ohio EPA Division of Air Pollution Control	April 30, 2019	RIS submitted a RATA of its CEM system.
Ohio EPA DERR, Hazardous Waste Management	March 12, 13, and 14, 2019	Semi-Annual CEI. One violation was noted related to container management. The violation was abated at the time of the inspection.
Ohio EPA DERR, Hazardous Waste Management	March 5, 2019	RIS requested a 120-day extension to the Director’s Findings and Orders issued on December 5 th . On March 5 th the Director of Ohio EPA granted RIS permission to extend the December 5 th Orders for 120-days.
Ohio EPA DERR, Hazardous Waste Management	December 27, 2018	RIS voluntarily disclosed an instance of noncompliance related to waste storage. One cubic yard container was sampled and visually inspected as required by RIS’ WAP. However, the container began leaking. The container, including absorbents (e.g. spill pigs, floor dry, saw dust) used to cleanup any liquids, was overpacked and subsequently burned as on-site generated waste. As such, the generated debris caused the original waste to meet 40 CFR 268.3 requirements.
Ohio EPA DERR, Hazardous Waste Management	November 16, 2018	FCI. Four violations were noted related to container management. Violations were abated at the time of the inspection.
Ohio EPA DERR, Hazardous Waste Management	November 1, 2018	Groundwater Report Compliance Review. No violations were found.
Ohio EPA DERR, Hazardous Waste Management	September 10, 11 and 12, 2018	Semi-Annual CEI. No violations were found.
Ohio EPA DERR, Hazardous Waste Management	August 27, 2018 / December 5, 2018	RIS voluntarily disclosed an instance of noncompliance related to waste storage. The non-compliance was resolved prior to disclosure. Subsequently, RIS requested and was granted by the Director of Ohio EPA (Director’s Findings and Orders) permission to temporarily store hazardous waste in vans for 90-days. In December 2018, Ohio EPA issued a Director’s Final Findings and Orders that set forth a schedule for compliance.
Ohio EPA DERR, Hazardous Waste Management	August 16, 2018	RIS voluntarily disclosed an emergency push at its incinerator. Specifically, on July 29, 2018, a plastic pail lid blew off in the staging area of CSF. The pail, which had just been unloaded from a van and set aside along with two other pails of the same waste, subsequently caught fire. An Emergency Coordinator (EC) was notified immediately. The EC decided to immediately process the waste. The remaining two pails had evidence of pressure and were also processed immediately.
Ohio EPA DERR, Hazardous Waste Management	June 25, 2018	FCI. One violation was noted related to container management. The violation was abated at the time of the inspection.
Ohio EPA Division of Air Pollution Control	May 25, 2018	RIS voluntarily disclosed an instance of noncompliance in Title V Quarterly Report pertaining to discharge of combustion gases to be emitted into the atmosphere that contain carbon monoxide in excess of RIS hourly rolling average.
Ohio EPA Division of Environmental Response and Revitalization	March 12, 13 and 14, 2018	Semi-Annual CEI. One violation was noted related to container management. The violation was abated at the time of the inspection.
Ohio EPA Division of Air Pollution Control	February 12, 2018	RIS voluntarily disclosed an instance of noncompliance in Title V Quarterly Report pertaining to discharge of combustion gases to be emitted into the atmosphere that contain carbon monoxide in excess of RIS hourly rolling average.
Ohio EPA DERR, Hazardous Waste Management	November 14, 2017	FCI. Two violations were noted related to container management. Violations were abated at the time of the inspection, or shortly thereafter.



Compliance History

September 2016 – April 2022

Agency	Inspection Date / Other	Summary of Results
Ohio EPA DERR, Hazardous Waste Management	September 6 and September 7, 2017	Semi-Annual CEI. No violations were found.
Ohio EPA Division of Air Pollution Control	May 24, 2017	On May 24, 2017, the OEPA DAPC conducted an air inspection of the Facility. No violations were found.
Ohio EPA Division of Materials and Waste Management	May 18, 2017	Post-Closure Compliance Inspection. No violations were found.
Ohio EPA Division of Materials and Waste Management	March 13 and March 16, 2017	Semi-Annual CEI. Two violations were noted related to container management. Violations were abated at the time of the inspection.
Ohio EPA Division of Materials and Waste Management	November 14, 2016	RIS voluntarily disclosed an instance of noncompliance. To resolve the violation and prevent reoccurrence RIS has implemented additional procedural checks and balances to ensure compatibility guidelines are followed at all times. RIS received a letter indicating its Return to Compliance dated January 17, 2017.
U.S. EPA, NEIC	September 26 through September 30, 2016	U.S. EPA conducted a waste-focused inspection of the facility. On February 27, 2018, RIS received a letter from U.S. EPA noting SubPart CC violations related to tank monitoring, and waste repackaging. As a result, RIS responded on March 8, 2018 and May 7, 2018 documenting: the use of a revised a calibration method for monitoring equipment; replacement of tank valve identification tags; and RIS' repackaging processes. On July 8, 2020, U.S. EPA issued a response stating that RIS' operational unit used during waste repackaging (barge) constituted waste storage without a permit. RIS disagreed with the allegation as the barge is only used to repack waste and does not function as a tank or a storage unit. On August 23, 2021, RIS and U.S. EPA entered into a Consent Agreement and Final Order ("CAFO") regarding the use of the barge at RIS. Under the agreement RIS will continue use of the barge to repack bulk wastes. RIS also agreed to pay a fine of \$20,015. In addition, RIS agreed to add a description of the operations conducted within the barge into its State and Federal RCRA Permits.
Ohio EPA Division of Materials and Waste Management	September 19 – 21, 2016	Semi-Annual CEI. No violations noted.